

# LIQUID MEMBRANES





---

## About ARDEX

---

ARDEX specialises in high-quality construction materials for substrate preparation, levelling floors, waterproofing, the fixing of natural stones & ceramic tiles and other surfacing materials. ARDEX offers innovative products of outstanding quality and optimal environmental friendliness, as well as providing training and support services for their application. The ARDEX Group comprises of 28 subsidiaries and some 1,400 employees active in offices and branches in more than 50 countries.

The history of ARDEX can be traced back over 50 years to Witten, Germany where ARDEX Chemie GmbH was founded by Herr and Frau Fortmann and Dr. Kraft. Products such as **Ardurit Z8** and **Ardur K15** are firmly established as benchmarks for flooring products worldwide.

In December 2001 ARDEX acquired Norcros Building Products (NBP). The latter has a similar heritage in the Australasian market with **Butynol waterproofing membranes, ABA tile adhesives** – renowned for their quality and technical excellence, a reputation built over 30 years. Innovations such as Abaflex are unique in the market until this day. Other brands offered by NBP include **Superflex** under-tile waterproofing systems, **Shelter (previously Dunlop)** sheet membrane systems and **HydrEpoxy** coatings. In 2002 **Vibro Products Pty Ltd**, manufacturers under licence of ARDEX floor levelling and adhesives, was acquired and integrated into ARDEX.

These brands, leaders in their respective fields, come together under the ARDEX umbrella, offering you expert solutions. In addition, sharing of resources and technology within our extensive network enables us to provide you with a broader range of world benchmarked products and services.

Make ARDEX your single point of contact for all your waterproofing, flooring and tiling needs.

### The Ardex Vision

***Ardex New Zealand aims to become New Zealand's leading supplier of high-quality specialised construction materials.***

---

**THIS PRODUCT MANUAL TAKES EFFECT FROM 1ST APRIL 2005 AND REPLACES ALL PREVIOUS PRODUCT MANUALS ISSUED BY ARDEX NEW ZEALAND LTD**

*® Butynol, Shelterbit, Shelterseal, Sheltercoat, Episeal and Fibrepol are registered tradenames.*



---

# Superflex Liquid System

---

Undertile Waterproofing Membranes for internal & external use

BRANZ Appraised

Certificate numbers 472 (2005), 473 (2005)



**SPECIFY WITH  
CONFIDENCE**

**BRANZ Appraisals**

**Technical Assessments of  
products for building and  
construction**

**BRANZ  
APPRAISAL  
CERTIFICATE  
No. 472 (2005)**

**SUPERFLEX™  
WET AREA  
MEMBRANES**

**Ardex New Zealand Ltd**  
P O Box 19549  
Woolston  
Christchurch  
Tel: 03 384 3029  
Fax: 03 384 9779



BRANZ Limited	BRANZ Pty Ltd
Private Bag 50 908	P O Box 830
Porirua City	Brookvale
New Zealand	NSW 2100
Tel: +64 4 237 1170	Australia
Fax: +64 4 237 1171	Tel: +61 2 9938 6011
www.branz.co.nz	Fax: +61 2 9938 6911



## Product

1.1 Superflex™ Wet Area Membranes are premixed and two-part, liquid applied waterproofing membranes for use under ceramic tiles in internal wet areas.



## Scope

2.1 Superflex™ Wet Area Membranes have been appraised for use as waterproofing membranes for internal wet areas of buildings, within the following scope:

- on floor substrates of concrete, flooring grade particleboard, plywood, and fibre cement sheet tile underlay, and on wall substrates of wet area fibre cement sheet lining systems and wet area plasterboard lining systems; and,
- when protected from physical damage by ceramic tiles; and,
- where floors are designed and constructed such that deflections do not exceed 1/360<sup>th</sup> of the span.

2.2 The use of Superflex™ Wet Area Membranes on concrete slabs where hydrostatic or vapour pressure is present is outside the scope of this Certificate.

2.3 Movement and control joints in the substrate must be carried through to the tile finish. The design and construction of the substrate and movement and control joints is specific to each building and therefore the responsibility of the building designer and building contractor and is outside the scope of this Certificate.

2.4 Ceramic tile finishes are outside the scope of this Certificate.

2.5 The products must be installed in accordance with the Ardex New Zealand Ltd Technical Literature referred to in Paragraph 6.1 and by Ardex trained and approved applicators.

## Building Regulations

### New Zealand Building Code (NZBC)

**3.1** In the opinion of BRANZ, Superflex™ Wet Area Membranes if designed, used, installed and maintained in accordance with the statements and conditions of this Certificate, will meet or contribute to meeting the following provisions of the NZBC:

**Clause B2 DURABILITY:** Performance B2.3.1 (b) 15 years. Superflex™ Wet Area Membranes meet this requirement. See Paragraph 9.1.

**Clause E3 INTERNAL MOISTURE:** Performance E3.3.6. Interior wet area floors and walls incorporating Superflex™ Wet Area Membranes will meet this requirement. Paragraphs 11.1 – 11.7.

**Clause F2 HAZARDOUS BUILDING MATERIALS:** Performance F2.3.1. Superflex™ Wet Area Membranes meet this requirement and will not present a health hazard to people.

**3.2** This Certificate appraises an Alternative Solution in terms of New Zealand Building Code compliance.

## Technical Specification

**4.1** Materials supplied by Ardex New Zealand Ltd are as follows:

### Superflex™ 1 Premixed Bathroom and Balcony

- A one part, polymer-based, ready-to-use, liquid-applied membrane containing micro-fibres, supplied as a light blue thixotropic paste in 6.5 kg (approximately 5 litres) and 20 kg (approximately 15 litres) pails.

### Superflex™ 3 Two Part Bathroom and Balcony

- A fast drying, two part, flexible, cementitious-based, liquid applied membrane containing micro-fibres. It is supplied as Superflex™ 3 Part A Liquid in 10 and 20 kg pails and Superflex™ 3 Part B Powder in 10 kg multi-wall bags. When dry, the membrane is light grey in colour.

### Superflex™ Primer

- A water-based primer used to seal substrates and enhance the adhesion of the membranes. It is supplied as a red coloured liquid in 20 kg plastic containers.

### Handling and Storage

**5.1** All materials must be stored inside, up off concrete floors, in dry conditions, out of direct sunlight and out of freezing conditions. The membrane products have a shelf life of 12 months from date of manufacture in the original unopened packaging. Once opened, the products must be used within 3 months.

## Technical Literature

**6.1** Refer to the Appraisals listing on the BRANZ website for details of the current Technical Literature for the Superflex™ Wet Area Membranes. The Technical Literature must be read in conjunction with this Certificate. All aspects of design, use, installation and maintenance contained in the Technical Literature and within the scope of this Certificate must be followed.

## Design Information

### General

**7.1** Superflex™ Wet Area Membranes are for use in buildings where an impervious waterproof membrane is required to floors

and walls to prevent damage to building elements and adjoining areas.

**7.2** Superflex™ 3 Two Part is designed to be used where a quicker curing time is required, such as in cool or humid conditions.

**7.3** The membranes must be protected from physical damage by the application of ceramic tile finishes.

**7.4** Movement and control joints may be required depending on the shape and size of the building or room, and the tile finish specified. Design guidelines can be found in the BRANZ Tiling Good Practice Guide.

**7.** Timber framing systems must comply with NZS 3604, or where specific engineering design is used, the framing shall be of at least equivalent stiffness to the framing provisions of NZS 3604, or comply with the serviceability criteria of NZS 4203. In all cases framing must be provided so that the maximum span of the substrate as specified by the substrate manufacturer is met and all sheet edges are fully supported. Timber framing systems supporting the substrates must be constructed such that deflections do not exceed 1/360<sup>th</sup> of the span. Where NZS 3604 is used, the allowable joist spans given in Table 7.1 shall be reduced by 20%.

## Substrates

### Plywood

**8.1** Plywood must be a minimum of 17mm thick complying with AS/NZS 2269, CD Grade Structural with sanded C face upwards and treated to H3.2 (CCA treated). LOSP treated plywood must not be used. The plywood must be supported with dwangs or framing with a maximum span of 400mm in each direction, fixed with 10g x 50mm stainless steel countersunk head screws at 150mm centres on the edges and 200mm through the body of the sheets.

### Fibre Cement Compressed Sheet/ Fibre Cement Sheet Tile Underlay

**8.2** Fibre cement compressed sheet must be manufactured to comply with the requirements of AS 2908.2 and must be specified by the manufacturer as being suitable for use as a wet area substrate. Fibre cement sheet tile underlay must be covered by a valid BRANZ Appraisal Certificate for use in internal wet areas. Installation must be in accordance with manufacturer's instructions.

### Particleboard

**8.3** Particleboard must be specified for the end use in accordance with NZS 3602.

### Concrete and Concrete Masonry

**8.4** Concrete and concrete masonry substrates must be to a specific engineering design meeting the requirements of the NZBC, such as concrete construction to NZS 3101 and NZS 3604 Concrete Slab-On-Ground Floors and Concrete masonry to NZS 4229 and NZS 4230.

### Wet Area Wall Linings

**8.5** Plasterboard wall linings must be manufactured to comply with AS/NZS 2588, and be covered by a valid BRANZ Appraisal Certificate for use in internal wet areas.

**8.6** Fibre Cement Sheet must be covered by a valid BRANZ Appraisal Certificate for use in wet areas.

## Durability

### Serviceable Life

**9.1** The Superflex™ Wet Area Membranes, when subjected to normal conditions of environment and use, are expected to have a serviceable life of at least 15 years and be compatible with tile finishes with a design service life of 15-25 years.

## Maintenance

**10.1** No maintenance of the membranes will be required provided significant substrate movement does not occur and the tile finish remains intact. Regular checks must be made of the tiled areas to ensure they are sound and will not allow moisture to penetrate. Any cracks or damage must be repaired

immediately by repairing the tiles, grouts and sealants.

10.2 In the event of damage to the membranes, the tiling must be removed and the membrane repaired by removing the damaged portion and applying a patch as for new work.

10.3 Drainage outlets must be maintained to operate effectively, and tile finishes must be kept clean.

## Internal Moisture

11.1 Superflex™ Wet Area Membranes when fully cured are impervious to water and when appropriately designed and installed will avoid the likelihood of water penetrating behind linings or entering concealed spaces.

11.2 Superflex™ Wet Area Membranes are suitable for use to achieve constraint of accidental overflow to meet NZBC Clause E3.3.2. A means of Code Compliance is given in NZBC Acceptable Solution E3/AS1 Paragraph 2.

11.3 Surfaces must be finished with ceramic tiles. A means of Code Compliance to NZBC Clause E3.3.3 is given in Acceptable Solution E3/AS1 Paragraph 3.1.1 (b) and 3.1.2 (b).

11.4 Falls in showers and shower areas must be a minimum of 1 in 50. In unenclosed showers, falls must extend a minimum of 1500 mm out from the shower rose. Floor wastes must be provided and the floor must fall to the outlet.

11.5 The waterproofing membrane must completely cover shower bases, and for unenclosed showers it must extend a minimum of 1500 mm out from the shower rose. Further design guidance on waterproofing wet areas, including waterproofing walls and junctions can be obtained from AS 3740, the BRANZ Tiling Good Practice Guide, and flooring and wallboard manufacturers.

11.6 Where water resistant wall finishes such as prefinished sheet materials are used, they must flash over the membrane a minimum of 30mm.

11.7 BRANZ recommends the entire floor be covered by a waterproof membrane for bath, shower and spa rooms where timber, plywood or particleboard floors are used. This is also a requirement of particleboard manufacturers.

## Installation Information

### Installation Skill Level Requirement

12.1 Installation of the membranes must be completed by approved applicators who have completed and passed the Ardex New Zealand Ltd training programme

12.2 Installation of substrates must be completed by tradespersons with an understanding of internal wet area construction, in accordance with instructions given within the Ardex New Zealand Ltd Technical Literature and this Certificate.

### Preparation of Substrates

13.1 Substrates must be dry and clean before installation commences. Surfaces must be even and free from nibs, sharp edges, dust, dirt or other materials such as oil, grease or concrete formwork release agents.

13.2 Concrete substrates can be checked for dryness by using a hygrometer as set out in BRANZ Bulletin No. 424. The relative humidity of the concrete must be 75% or less before membrane application.

13.3 All voids, cracks, holes, joints and excessively rough areas must be filled to achieve a smooth and uniform surface. Junctions of substrate abutments, such as at wall/floor junctions must have a bond breaker joint system installed as set out in the Technical Literature.

13.4 Substrates must be primed with Superflex™ Primer and allowed to cure before the membrane is installed.

### Membrane Installation

14.1 Installation must not be undertaken where the substrate surface temperature is below 10°C or above 35°C.

14.2 Superflex™ 3 Two Part Bathroom and Balcony liquid and dry components must be mixed and left to stand

for 5 minutes before re-mixing, then applying. Superflex™ 1 Premixed Bathroom and Balcony must be thoroughly stirred before application.

14.3 The membrane must be applied in a minimum of two coats at the rates set out in the Technical Literature to give a total finished thickness of 1.2 – 1.5 mm. Subsequent coats must be applied at an opposite direction to the previous coat.

14.4 Application can be made by roller (medium/long nap), brush (long bristle), or a flat steel trowel.

14.5 Reinforcement fabric is bedded into the wet layer between coats to provide movement protection at wall/wall and wall/floor junctions, and at any other areas such as joints in the flooring substrate, floor cracks or around penetrations in the membrane.

14.6 Clean up may be undertaken with water.

## Tiling

15.1 The membrane must be fully cured before tiling. The cured membrane must be protected at all times to prevent mechanical damage, so may require temporary covers until the finishing is completed.

15.2 Tiling must be undertaken in accordance with AS 3958.1 and the BRANZ Good Tiling Practice Guide. The compatibility of the tile adhesive must be confirmed with the adhesive manufacturer or Ardex New Zealand Ltd.

## Inspections

16.1 The Technical Literature must be referred to during the inspection of membrane installations by Building Consent Authorities and Territorial Authorities.

16.2 Critical areas of inspection for waterproofing systems are:

- Construction of substrates, including crack control and installation of bond breakers and movement control joints.
- Moisture content of the substrate prior to the application of the membrane.
- Acceptance of the substrate by the membrane installer prior to application of the membrane.
- Installation of the membrane to the manufacturer's instructions, particularly installation to the correct thickness.
- Membrane curing and integrity prior to the installation of tiles including protection from mechanical damage during curing and prior to tile installation.

## Health and Safety

17.1 Safe use and handling procedures for the membrane systems are provided in the Technical Literature. The products must be used in conjunction with the relevant materials safety data sheet for each membrane.

## Basis of Appraisal

The following is a summary of the technical investigations carried out:

### Tests

18.1 The following testing of Superflex™ 1 Premixed Bathroom and Balcony and Superflex™ Two Part Bathroom and Balcony has been undertaken by Ardex Australia Pty Ltd research and development laboratory: water vapour transmission; water absorption; tensile strength and elongation before and after UV exposure, immersion in bleach, immersion in industrial detergent and immersion in water. Test methods and results were reviewed by BRANZ and found to be satisfactory.

18.2 The following testing of Superflex™ 1 Premixed Bathroom and Balcony was undertaken by the Commonwealth Scientific Industrial Research Organisation (CSIRO) Australia:

- In accordance with ANSI A118.10 for ICBO Evaluation Service - dimensional stability; waterproofness; shear strength to ceramic tile and cement mortar; and fungal and micro-organism resistance.
- In accordance with AS 1145 – behaviour under cyclic

- In accordance with AS 1145 – behaviour under cyclic strain.

Test methods and results were reviewed by BRANZ and found to be satisfactory.

18.3 Testing of Superflex™ 1 Premixed Bathroom and Balcony and Superflex™ 3 Two Part Bathroom and Balcony has been undertaken by BRANZ for low temperature flexibility and peel adhesion after heat/humidity aging.

18.4 Testing for suitability over particleboard in accordance with AS/NZS 4858-2004, Appendix C has not been undertaken because compliance with the standard has been met by satisfactory water vapour transmission test results.

## Other Investigations

19.1 An assessment was made of the durability of the Superflex™ Wet Area Membranes by BRANZ technical experts.

19.2 Site visits have been carried out by BRANZ to assess the practicability of installation, and to examine completed installations.

19.3 The Technical Literature has been examined by BRANZ and found to be satisfactory.

## Quality

20.1 The manufacture of the Superflex™ products by Ardex Australia Pty Ltd has been examined by BRANZ, and details regarding the quality and composition of the materials used were obtained by BRANZ and found to be satisfactory.

20.2 The quality management system of Ardex Australia Pty Ltd has been assessed and registered as complying with the requirements of AS/NZS ISO 9001:2000 by SAI Global, Certificate Number QEC1219.

20.3 The quality of manufacture of the Superflex™ products is the responsibility of Ardex Australia Pty Ltd.

20.4 The quality of supply of the Superflex™ products to the market is the responsibility of Ardex New Zealand Ltd.

20.5 Quality on site is the responsibility of the trained and approved applicators.

20.6 Designers are responsible for the substrate design, and building contractors are responsible for the quality of construction of substrate systems in accordance with the instructions of the substrate manufacturer, Ardex New Zealand Ltd and this Certificate.

20.7 Building owners are responsible for the maintenance of the tiling systems in accordance with Ardex New Zealand Ltd's instructions.

## Sources of Information

- AS 2908.2: 2000 Cellulose-cement products - flat sheet.
- AS 3740 – 2004 Waterproofing of wet areas within residential buildings.
- AS 3958.1 1991 Guide to the installation of ceramic tiles.
- ASTM D2919-01 Standard test method for determining durability of adhesive joints stressed in shear by tension loading.
- AS/NZS 4858 - 2004 Wet area membranes.
- AS/NZS 2269:1994 Plywood - Structural.
- NZS 3101: 1995 The design of concrete structures.
- NZS 3602: 2003 Timber and wood-based products for use in buildings.
- NZS 3604: 1999 Timber framed buildings.
- NZS 4229:1999 Concrete masonry buildings not requiring specific engineering design.
- NZS 4230:1990 Code of practice for the design of masonry structures.
- New Zealand Building Code Handbook and Approved Documents, Building Industry Authority, 1992.
- The Building Regulations 1992, up to, and including October 2004 Amendment.
- Tiling Good Practice Guide, BRANZ, March 2004.
- Membrane Roofing Good Practice Guide, BRANZ , November 1999



**In the opinion of BRANZ, Superflex™ Wet Area Membranes are fit for purpose and will comply with the Building Code to the extent specified in this Certificate provided they are used, designed, installed and maintained as set out in this Certificate.**

**The Appraisal Certificate is issued only to the Certificate Holder, Ardex New Zealand Ltd, and is valid until further notice, subject to the Conditions of Certification.**

## Conditions of Certification

1. This Certificate:
  - a) relates only to the product as described herein;
  - b) must be read, considered and used in full together with the technical literature;
  - c) does not address any Legislation, Regulations, Codes or Standards, not specifically named herein;
  - d) is copyright of BRANZ.
2. The Certificate Holder:
  - a) continues to have the product reviewed by BRANZ;
  - b) shall notify BRANZ of any changes in product specification or quality assurance measures prior to the product being marketed;
  - c) abides by the BRANZ Appraisals Services Terms and Conditions.
3. The product and the manufacture are maintained at or above the standards, levels and quality assessed and found satisfactory by BRANZ.
4. BRANZ makes no representation as to:
  - a) the nature of individual examples of, batches of, or individual installations of the product, including methods and workmanship;
  - b) the presence or absence of any patent or similar rights subsisting in the product or any other product;
  - c) any guarantee or warranty offered by the Certificate Holder.
5. Any reference in this Certificate to any other publication shall be read as a reference to the version of the publication specified in this Certificate.

For BRANZ

P Robertson  
Chief Executive

Date of issue: 20 June 2005



**SPECIFY WITH  
CONFIDENCE**

**BRANZ Appraisals**

**Technical Assessments of  
products for building and  
construction**

**BRANZ  
APPRAISAL  
CERTIFICATE  
No. 473 (2005)**

**SUPERFLEX™  
EXTERNAL**

**Ardex New Zealand Ltd**  
P O Box 19549  
Woolston  
Christchurch  
Tel: 03 384 3029  
Fax: 03 384 9779



BRANZ Limited	BRANZ Pty Ltd
Private Bag 50 908	P O Box 830
Porirua City	Brookvale
New Zealand	NSW 2100
Tel: +64 4 237 1170	Australia
Fax: +64 4 237 1171	Tel: +61 2 9938 6011
www.branz.co.nz	Fax: +61 2 9938 6911



## Product

1.1 Superflex™ External Waterproofing Membranes are liquid applied waterproofing membranes for use under ceramic tile finishes on external decks and balconies.



## Scope

2.1 Superflex™ External Waterproofing Membranes have been appraised for use as waterproofing membranes for buildings within the following scope:

- scope limitations of NZBC Acceptable Solution E2/AS1, Paragraph 1.1; and,
- with timber supporting structures designed and constructed in accordance with the NZBC; and,
- with substrates of fibre cement compressed sheet; and,
- with decks that have a maximum size of 40m<sup>2</sup>.

2.2 Superflex™ External Waterproofing Membranes have also been appraised for use as waterproofing membranes for external reinforced concrete pedestrian decks and balconies for buildings within the following scope:

- up to 3 storeys with a maximum height from ground to eaves of 10m and with a floor plan area limited only by seismic and structural control joints; and,
- with the reinforced concrete structure designed and constructed in accordance with the NZBC.

2.3 This Appraisal is limited to decks and balconies within the following scope:

- constructed to suitable falls (Refer Paragraph 12.1 – 12.9); and,
- with the membranes continually protected from exposure to UV (ultra violet) light and from physical damage by ceramic tile finishes; and,
- with decks and balconies designed and constructed such that deflections do not exceed 1/360<sup>th</sup> of the span; and,
- with no steps within the deck level, no integral roof gardens and no down pipe discharging directly onto the deck.

2.4 Movement and control joints in the substrate must be carried through to the tile finish. The design and construction of the substrate and movement and control joints is specific to each building, and therefore the responsibility of the building designer and building contractor and is outside the scope of this Certificate.

2.5 Ceramic tile finishes are outside the scope of this Certificate.

2.6 The membranes must be installed in accordance with the Ardex New Zealand Ltd Technical Literature referred to in Paragraph 6.1 and by Ardex trained and approved applicators

## Building Regulations

### New Zealand Building Code (NZBC)

**3.1 In the opinion of BRANZ, Superflex™ External Waterproofing Membranes, if designed, used, installed and maintained in accordance with the statements and conditions of this Certificate, will meet or contribute to meeting the following provisions of the NZBC:**

**Clause B2 DURABILITY:** Performance B2.3.1 (b) 15 years. Superflex™ External Waterproofing Membranes meet this requirement. See Paragraph 9.1.

**Clause E2 EXTERNAL MOISTURE:** Performance E2.3.1 and E2.3.2. Decks and balconies incorporating Superflex™ External Waterproofing Membranes meet this requirement. See Paragraphs 12.1 – 12.9.

**Clause F2 HAZARDOUS BUILDING MATERIALS:** Performance F2.3.1. Superflex™ External Waterproofing Membranes meet this requirement and will not present a health hazard to people.

3.2 This Certificate appraises an Alternative Solution in terms of New Zealand Building Code Compliance.

## Technical Specification

4.1 Materials supplied by Ardex NZ Ltd are as follows:

### Superflex™ 1 Premixed Bathroom and Balcony

- A one part, polymer-based, ready-to-use, liquid-applied membrane containing micro-fibres, supplied as a light blue thixotropic paste in 6.5 kg (approximately 5 litres) and 20 kg (approximately 15 litres) pails.

### Superflex™ 3 Two Part Bathroom and Balcony

- A fast drying, two part, flexible, cementitious-based, liquid applied membrane containing micro-fibres. It is supplied as Superflex™ 3 Part A Liquid in 10 and 20 kg pails and Superflex™ 3 Part B Powder in 10 kg multi-wall bags. When dry, the membrane is light grey in colour.

### Superflex™ Primer

- A water-based primer used to seal substrates and enhance the adhesion of the membranes. It is supplied as a red coloured liquid in 20 kg plastic containers.

## Handling and Storage

5.1 All materials must be stored inside, up off concrete floors, in dry conditions, out of direct sunlight and out of freezing conditions. The membrane products have a shelf life of 12 months from date of manufacture in the original unopened packaging. Once opened, the products must be used within 3 months.

## Technical Literature

6.1 Refer to the Appraisals listing on the BRANZ website for details of the current Technical Literature for the Superflex™ External Waterproofing Membranes. The Technical Literature must be read in conjunction with this Certificate. All aspects of design, use, installation and maintenance contained in the Technical Literature and within the scope of this Certificate must be followed.

## Design Information

### General

7.1 Superflex™ External Waterproofing Membranes are for use on decks and balconies where an impervious waterproof

membrane is required to prevent damage to building elements and adjoining areas.

7.2 The Superflex™ 3 Two Part Bathroom and Balcony product is designed to be used where a quicker curing time is required, such as in cool or humid conditions.

7.3 The membranes must be protected from exposure to UV light and from physical damage by ceramic tile finishes.

7.4 The effective control of internal moisture must be considered at the design stage due to the impermeability of the membrane. Refer to BRANZ publication “Good Practice Guide to Membrane Roofing.”

7.5 Movement and control joints may be required depending on the shape and size of the deck, and the finish specified. Design guidelines for control joints for tiles can be found in the BRANZ Tiling Good Practice Guide.

7.6 Timber framing systems must comply with NZS 3604, or where specific engineering design is used, the framing shall be of at least equivalent stiffness to the framing provisions of NZS 3604, or comply with the serviceability criteria of NZS 4203. In all cases framing must be provided so that the maximum span of the substrate as specified by the substrate manufacturer is met and that all sheet edges are fully supported. Timber framing systems supporting the substrates must be constructed such that deflections do not exceed 1/360<sup>th</sup> of the span. Where NZS 3604 is used, the allowable joist spans given in Table 7.1 shall be reduced by 20%.

## Substrates

### Fibre Cement Compressed Sheet

8.1 Fibre cement compressed sheet must be manufactured to comply with the requirements of AS 2908.2 and must be specified by the manufacturer as being suitable for use as an external decking substrate. The fibre cement sheet must be of a thickness to meet specific structural design requirements and must be secured to the structure to resist wind uplift and all other forces acting on the deck or balcony, such as deflection from gravity and live loads. Installation must be in accordance with instructions of the manufacturer.

### Concrete

8.2 Concrete substrates must be to a specific engineering design meeting the requirements of the NZBC, such as concrete construction to NZS 3101.

## Durability

### Serviceable Life

9.1 Superflex™ External Waterproofing Membranes, when subjected to normal conditions of environment and use, are expected to have a serviceable life of at least 15 years and be compatible with tiling finishes with a design service life of 15-25 years.

## Maintenance

10.1 No maintenance of the membranes will be required provided significant substrate movement does not occur and the finish course remains intact. Regular checks must be made of the tiling to ensure it is sound. Any cracks or damage must be repaired immediately by repairing the tiling and any grout or sealant.

10.2 In the event of damage to the membranes, the tiling course must be removed and the membrane repaired by removing the damaged portion and applying a patch as for new work.

10.3 Drainage outlets must be maintained to operate effectively, and finish courses must be kept clean. Cleaning materials that may affect polymer based membranes must not be used.

## Outbreak of Fire

11.1 The membranes must be protected from heat sources such as flues and chimneys in accordance with the requirements of NZBC Acceptable Solution C/AS1 Part 9 for the protection of combustible materials.

## External Moisture

12.1 Decks and balconies must be designed and constructed to shed precipitated moisture. They must also take account of snowfalls in snow prone areas. A means of meeting code compliance with NZBC Clause E2.3.1 is given by the Technical Literature which gives details aligned with NZBC Acceptable Solution E2/AS1.

12.2 When installed in accordance with this Certificate and the Technical Literature, Superflex™ External Waterproofing Membranes will prevent the penetration of water and will therefore meet code compliance with Clause E2.3.2. The membranes are impervious to water and will give a weathertight deck or balcony.

12.3 The minimum fall to decks, balconies and gutters must be 1 in 60 and all falls must slope to an outlet. Inadequate falls will allow moisture to collect and increase the risk of deterioration of the membrane and tiling finish.

12.4 Superflex™ External Waterproofing membranes are impermeable; therefore a means of dissipating construction moisture must be provided in the building design and construction to meet code compliance with Clause E2.3.6.

12.5 Deck and balcony falls must be built into the substrate and not created with mortar screeds applied over the membrane.

12.6 Allowance for deflection and settlement of the substrate must be made in the design of the deck or balcony to ensure falls are maintained and no ponding of water can occur.

12.7 Drainage flanges must be used for any outlet and must be fitted with a grate or cage to reduce potential sources of blockages. An overflow must be provided where the deck or balcony does not drain to an external gutter or spouting.

12.8 Penetrations and upstands of the membranes must be raised above the level of any possible flooding caused by blockage of deck and balcony drainage.

12.9 The design of details not covered by the Technical Literature is subject to specific weathertightness design and is outside the scope of this Certificate.

## Installation Information

### Installation Skill Level Requirement

13.1 Installation of the membranes must be completed by approved applicators that have completed and passed the Ardex New Zealand Ltd training programme.

13.2 Installation of substrates must be completed by tradespersons with an understanding of deck and balcony construction, in accordance with instructions given within the Ardex New Zealand Ltd Technical Literature and this Certificate.

### Preparation of Substrates

14.1 Substrates must be dry, clean and stable before installation commences. Surfaces must be smooth and free from nibs, sharp edges, dust, dirt or other materials such as oil, grease or concrete formwork release agents. All surface defects must be filled to achieve an even and uniform surface.

14.2 Concrete substrates can be checked for dryness by using a hygrometer, as set out in BRANZ Bulletin No. 424. The relative humidity of the concrete must be 75% or less before membrane application.

14.3 The moisture content of a timber substructure must be a maximum of 20% and fibre cement sheet must be dry at time of membrane application. This will generally require fibre cement sheets to be covered until just before the membrane is laid, to prevent rain wetting.

14.4 Substrates must be primed with Superflex™ Primer and allowed to cure before the membrane is installed.

### Membrane Installation

15.1 Installation must not be undertaken where the substrate surface temperature is below 10°C or above 35°C.

15.2 Superflex™ 3 Two Part Bathroom and Balcony liquid and dry components must be mixed and left to stand for 5 minutes before re-mixing, then applying. Superflex™ 1

Premixed Bathroom and Balcony must be thoroughly stirred before application.

15.3 The membrane must be applied in a minimum of two coats at the rates set out in the Technical Literature to give a total finished thickness of 1.5 mm. Subsequent coats must be applied in an opposite direction to the previous coat.

15.4 Application can be made by roller (medium/long nap), brush (long bristle), or a flat steel trowel.

15.5 Reinforcement fabric is bedded into the wet layer between coats to provide movement protection at wall/wall and wall/floor junctions, or any other areas such as joints in the flooring substrate, floor cracks, or around penetrations in the membrane.

15.6 It is strongly recommended to protect the membrane with temporary covers until it is fully cured in case of mechanical damage or rain wetting.

15.7 Clean up may be undertaken with water.

## Tiling

16.1 The membrane must be fully cured before tiling. The cured membrane must be protected at all times to prevent mechanical damage, so may require temporary covers until the finishing is completed.

16.2 Tiling must be undertaken in accordance with AS 3958.1 and the BRANZ Good Tiling Practice Guide. The compatibility of the tile adhesive must be confirmed with the adhesive manufacturer or Ardex New Zealand Ltd.

## Inspections

17.1 The Technical Literature must be referred to during the inspection of membrane installations by Building Consent Authorities and Territorial Authorities.

17.2 Critical areas of inspection for waterproofing systems are:

- Construction of substrates, including crack control and installation of bond breakers and movement control joints.
- Moisture content of the substrate prior to the application of the membrane.
- Acceptance of the substrate by the membrane installer prior to application of the membrane.
- Installation of the membrane to the manufacturer's instructions, particularly installation to the correct thickness.
- Membrane curing and integrity prior to the installation of tiles, including protection from moisture, frost and mechanical damage during curing.

## Health and Safety

19.1 Safe use and handling procedures for the membrane systems are provided in the Technical Literature. The products must be used in conjunction with the relevant materials safety data sheet for each membrane.

## Basis of Appraisal

The following is a summary of the technical investigations carried out:

### Tests

20.1 The following testing of Superflex™ 1 Premixed Bathroom and Balcony and Superflex™ 3 Two Part Bathroom and Balcony has been undertaken by Ardex Australia Pty Ltd research and development laboratory: water vapour transmission; water absorption; tensile strength and elongation before and after UV exposure, immersion in bleach, immersion in industrial detergent and immersion in water. Test methods and results were reviewed by BRANZ and found to be satisfactory.

20.2 The following testing of Superflex™ 1 Premixed Bathroom and Balcony was undertaken by the Commonwealth Scientific Industrial Research Organisation (CSIRO) Australia:

- In accordance with ANSI A118.10 for ICBO Evaluation Service - dimensional stability; waterproofness; shear strength to ceramic tile and cement mortar; and fungal and

micro-organism resistance.

- In accordance with AS 1145 – behaviour under cyclic strain.

Test methods and results were reviewed by BRANZ and found to be satisfactory.

20.3 Testing of Superflex™ 1 Premixed Bathroom and Balcony and Superflex™ 3 Two Part Bathroom and Balcony has been undertaken by BRANZ for low temperature flexibility and peel adhesion after heat/humidity aging.

20.4 Testing for suitability over particleboard in accordance with AS/NZS 4858-2004, Appendix C has not been undertaken because compliance with the standard has been met by satisfactory water vapour transmission test results.

## Other Investigations

21.1 An assessment was made of the durability of the Superflex™ External Waterproofing Membranes by BRANZ technical experts.

21.2 Site visits have been carried out by BRANZ to assess the practicability of installation, and to examine completed installations.

21.3 The Technical Literature has been examined by BRANZ and found to be satisfactory.

## Quality

22.1 The manufacture of the Superflex™ products by Ardex Australia Pty Ltd has been examined by BRANZ, and details regarding the quality and composition of the materials used were obtained by BRANZ and found to be satisfactory.

22.2 The quality management system of Ardex Australia Pty Ltd has been assessed and registered as complying with the requirements of AS/NZS ISO 9001:2000 by SAI Global, Certificate Number QEC1219.

22.3 The quality of manufacture of the Superflex™ products is the responsibility of Ardex Australia Pty Ltd.

22.4 The quality of supply of the Superflex™ products to the market is the responsibility of Ardex New Zealand Ltd.

22.5 Quality on site is the responsibility of Ardex trained and approved applicators.

22.6 Designers are responsible for the substrate design, and building contractors are responsible for the quality of construction of substrate systems in accordance with the instructions of the substrate manufacturer, Ardex New Zealand Ltd and this Certificate.

22.7 Building owners are responsible for the maintenance of the tiling systems in accordance with the instructions of Ardex New Zealand Ltd's instructions.

## Sources of Information

- AS 2908.2: 2000 Cellulose-cement products - Flat sheet.
- AS 3958.1 Guide to the installation of ceramic tiles.
- AS/NZS 2269:1994 Plywood - Structural.
- NZS 3101: 1995 The design of concrete structures.
- NZS 3604: 1999 Timber framed buildings.
- Approved Document for New Zealand Building Code External Moisture Clause E2, Building Industry authority, Third Edition June 2004.
- New Zealand Building Code Handbook and Approved Documents, Building Industry Authority, 1992.
- The Building Regulations 1992, up to, and including October 2004 Amendment.
- Tiling Good Practice Guide, BRANZ, March 2004.
- Membrane Roofing Good Practice Guide, BRANZ, November 1999.

## NZBC Acceptable Solution E2/AS1

References to NZBC Acceptable Solution E2/AS1 in this Certificate are to NZBC Acceptable Solution E2/AS1 Third Edition June 2004.



**In the opinion of BRANZ, Superflex™ External Waterproofing Membranes are fit for purpose and will comply with the Building Code to the extent specified in this Certificate provided they are used, designed, installed and maintained as set out in this Certificate.**

**The Appraisal Certificate is issued only to the Certificate Holder, Ardex New Zealand Ltd, and is valid until further notice, subject to the Conditions of Certification.**

### Conditions of Certification

1. This Certificate:
  - a) relates only to the product as described herein;
  - b) must be read, considered and used in full together with the technical literature;
  - c) does not address any Legislation, Regulations, Codes or Standards, not specifically named herein;
  - d) is copyright of BRANZ.
2. The Certificate Holder:
  - a) continues to have the product reviewed by BRANZ;
  - b) shall notify BRANZ of any changes in product specification or quality assurance measures prior to the product being marketed;
  - c) abides by the BRANZ Appraisals Services Terms and Conditions.
3. The product and the manufacture are maintained at or above the standards, levels and quality assessed and found satisfactory by BRANZ.
4. BRANZ makes no representation as to:
  - a) the nature of individual examples of, batches of, or individual installations of the product, including methods and workmanship;
  - b) the presence or absence of any patent or similar rights subsisting in the product or any other product;
  - c) any guarantee or warranty offered by the Certificate Holder.
5. Any reference in this Certificate to any other publication shall be read as a reference to the version of the publication specified in this Certificate.

For BRANZ

P Robertson  
Chief Executive

Date of issue: 20 June 2005





---

# ARDEX WPM 001

**Superflex Bathroom & Balcony Premixed - 1 Part**

---

Undertile Waterproofing Membrane

BRANZ Appraised

# ARDEX WPM 001

## Superflex Bathroom & Balcony Premixed - 1 Part Undertile Waterproofing Membrane

### BRANZ APPRAISED

BRANZ Appraisal Certificates No 472 (2005) and No 473 (2005) have been issued. Separate copies available on request.



### PRODUCT DESCRIPTION

Ardex WPM 001 (Superflex Premixed) is a tough, ready to use waterproofing membrane specifically designed for use under tiles. Ardex WPM 001 (Superflex Premixed) has been uniquely formulated with synthetic microfibres to increase its strength and eliminate the need for a separate reinforcement mat. Ardex WPM 001 (Superflex Premixed) is based on the most advanced acrylic polymer technology, and is totally resistant to re-emulsification.

Ardex WPM 001 (Superflex Premixed) is flexible, safe to use, low in odour, and is fully compatible with polymer modified tile adhesives. Ardex WPM 001 (Superflex Premixed) is one of the fastest drying one part acrylic membranes on the market - normally ready to tile in 48 hours @ 23°C.

### FEATURES/BENEFITS

Fast drying Ardex WPM 001 (Superflex Premixed) can be tiled over in 48 hours in non critical areas\*.

#### Features Benefits

- Liquid reinforced: Excellent strength, eliminates need for reinforcing mat.
- Flexible: Accommodates normal building movement.
- Advanced acrylic: Will not re-emulsify polymers.
- Designed for tiling - Fully compatible with ABA tile systems adhesives.
- Water based Safe to use, low odour & easy cleaning. BRANZ/CSIRO Appraisals Approved for undertile waterproofing in shower recesses by independent testing authority.

#### CSIRO Appraisal #91

\*Critical areas include areas where the membrane is applied at greater than 0.5mm or over impermeable substances such as over bond breakers or incorporating other reinforcement. Longer drying times are necessary in these areas.

### APPLICATION RANGE

#### Performance Levels

Commercial and residential.

#### Location

Internal wet areas, balconies, decks, and other areas that will be tiled or otherwise protected from regular foot traffic.

### Surfaces

Walls & floors.

### Substrates

#### Concrete

Cured for min. 28 days or sealed when set with one coat. Ardex HydrEpoxy 300 at a coverage rate of 3.0 square metres per litre and allowed to cure overnight. Wet concrete should be allowed to dry thoroughly or sealed with one coat of Ardex HydrEpoxy 300 as above.

#### Renders and Screeds

Cured for min. 7 days or sealed when set with one coat Ardex HydrEpoxy 300 at a coverage rate of 3.0 square metres per litre and allowed to cure overnight. Wet render should be allowed to dry thoroughly or sealed with one coat of Ardex HydrEpoxy 300 as above.

#### Fibre Cement

Suitable for wet area grade fibre cement.

#### Plasterboard

Wet area grade only.

#### Plywood

Structural plywood (PAA branded) or marine grade (Internal use only).

#### Particleboard

Wet area grade, internal use only (special preparation is required - contact Ardex).

#### Primer

Water Based. Superflex Primer is a 1 Part water based primer.

### SPECIFICATION CLAUSE

#### Ardex WPM 001 (Superflex Premixed)

The waterproofing membrane shall be Ardex WPM 001 (Superflex Premixed): a one part acrylic modified fibre reinforced membrane formulated to provide a tough, long lasting water barrier under tiling systems.

### PACKAGING

20L PVC Pails.

### SHELF LIFE

12 months when stored in the original unopened packaging, in a dry place at 23°C. Do not store in direct sunlight. Replace lid tightly after use. Use remaining contents from part used containers within 3 months.

## COVERAGE

Two coats are recommended for an effective waterproof membrane.

Coverage will vary depending on the porosity of the surface.

One 20kg (15 litre) unit will cover approximately 9-11m<sup>2</sup> (based on two coats) depending on area requirements between wall and floor surfaces to be treated.

## DRYING TIMES

### Recoat time

1-2 hours (23°C, 50% RH) at between first and second coats. Alternatively, if a polyester mat is used between coats then the second coat can be applied whilst the first coat is still wet.

### Dry through

The slowest drying areas are those where the membrane has been applied over a silicone bond breaker, eg. wall and floor junctions. The membrane cannot be tiled over until these critical areas are completely dry. Ardex WPM 001 (Superflex Premixed) is totally dry in 48 hours at 23°C, 50% RH, but can take up to 72 hours at 10°C, 50% RH in corners or for thick films.

### Fully cured

The shower should not be used until the membrane has reached its full strength. The Ardex WPM 001 (Superflex Premixed) membrane is fully cured after 3 days at 23°C, or after 5 days at 10°C.

Drying times will vary depending on humidity, surface temperature and surface porosity.

Do not apply on substrates where the surface temperature is below 10°C or above 35°C.

## CLEANING

Wash hands, brushes, rollers, etc, with water while the membrane is still fresh. Remove cured material with mineral turpentine.

## PRECAUTIONS

Do not use the product in the following situations:

- Areas subject to negative hydrostatic pressure or rising damp
- Where the substrate is wet - wet surfaces can be sealed with one coat Ardex HydrEpoxy 300 at a coverage rate of 3.0 square metres per litre and allowed to cure overnight
- Where rain is imminent
- Where the membrane will be left exposed and subjected to regular foot traffic
- On glazed, glass or other totally impervious

surfaces (eg. areas pre-treated with water repellants)

- Where the surface temperature is below 10°C or greater than 35°C
- All floor areas must have adequate falls either built into the substrate or achieved with a sand/cement screed prior to application of the Ardex WPM 001 (Superflex Premixed).

For substrates or situations other than those listed contact Ardex.

## SAFETY DATA

Ardex WPM 001 (Superflex Premixed) is non-toxic. However, the contents should not be swallowed or inhaled. In case of eye contamination, rinse thoroughly with clean water. If irritation continues seek medical advice.

Material Safety Data sheets are available from Ardex upon request.

## QUALITY PRODUCT

Ardex WPM 001 (Superflex Premixed) is manufactured and tested to Ardex procedures which are maintained in accordance with Quality System Standard ISO 9001.

## USER NOTES

The technical details and recommendations contained in this data sheet are given in good faith and represent the best of our knowledge and experience at the time of printing. It is the responsibility of the user to ensure that the product is used in accordance with Ardex instructions and in applications for which they are intended.

## APPLICATION

Apply Ardex WPM 001 (Superflex Premixed) by brush or roller. A medium nap (8-12mm pile) paint roller is recommended. New rollers should be dampened with water before being used for the first time.

For best results with a paint brush use a good quality, 50mm long bristle variety.

To achieve the required dry film thickness per coat application must consist of laying the product onto the surface. Do not try lightly to apply in the same manner as a building paint. A conventional building paint is normally applied at 25-40 microns for wet film thickness while Ardex WPM 001 (Superflex Premixed) needs to be applied at between 0.5 and 1.0mm per coat depending on application.

# ARDEX WPM 001

## Superflex Bathroom & Balcony Premixed - 1 Part Undertile Waterproofing Membrane

### CRITICAL AREAS

#### Internal wet areas (Refer Fig.1)

1. Construction should be in accordance with Australian/New Zealand Standard 3740-2004.
2. All render and tile bed requirements should be completed before application of the membrane and tiles or other floor coverings should be direct bonded to the membrane.
3. Ensure wall & floor sheets are installed as per sheet manufacturer's recommendations.
4. Ensure suitable brick/concrete hobs are used (do not use timber), and that the top of the hob does not slope outwards.
5. Ensure that falls to the waste are min 1:60 (ie. approx. 30mm in 2m) before waterproofing. Ensure outlet pipes are fixed securely and that the waste or drainage flanges are recessed into the floor.
6. Avoid sheet joints in shower recess floor. Ensure that sheets are securely fixed to the wall at the bottom edge, and sheet joints are sealed with a neutral cured silicone sealant spread approximately 5mm on either side of the joint.
7. Treat nail and screw holes with neutral cure silicone sealant.
8. Seal the perimeters of taps, shower outlets and waste outlets with neutral cure silicone sealant.
9. Apply a bead of neutral cure silicone sealant to all horizontal and vertical corners.
10. Apply a bead of neutral cure silicone sealant to the junction of the hob or angle and walls.
11. Apply the membrane to the entire shower recess floor and down into waste or drainage flange. Apply the membrane over the hob and at least 100mm beyond the outside edge of the hob (ideally to entire wet area floor).
12. Apply the membrane 1800mm up the walls or to

the height of the shower rose within the shower recess.

13. Install the shower screen to inside edge of the hob.

#### Balconies and decks (Refer Fig.2)

1. Ensure that the deck is constructed with falls to edge/drains of min 1:100 (ie. 20mm in 2m) or else achieve the fall with a sand/cement screed.
2. Ensure a min set down (step down) of 150mm to the finished floor level (ie. top of tiles).
3. Ensure suitable flashing is installed, ideally prior to the installation of the balcony screen/ sliding door.
4. Treat any sheet joints with a neutral cure silicone prior to waterproofing.
5. Prepare and seal all wall/floor junctions with a bead of neutral cure silicone.
6. Apply the membrane up the step down and as far up underneath the screen door flashing as possible (ideally waterproof prior to installing door).
7. Where possible, apply the membrane prior to building divisional walls.
8. Apply the membrane to the entire balcony floor and at least 50mm up the wall above the top surface of the finished tiles and finished below the wall drainage vents.
9. Apply the membrane to the top of the parapets and divisional walls, or else install suitable metal capping.
10. Apply the membrane down over the front edge of the balcony onto the drip rail.
11. Carefully seal any gaps around balcony penetrations prior to applying the membrane.
12. Apply the membrane down into outlets and drains, ensuring excess material is removed.
13. Ensure all weep holes are above the membrane application area.

Fig.1 - Shower Recess - Critical Areas

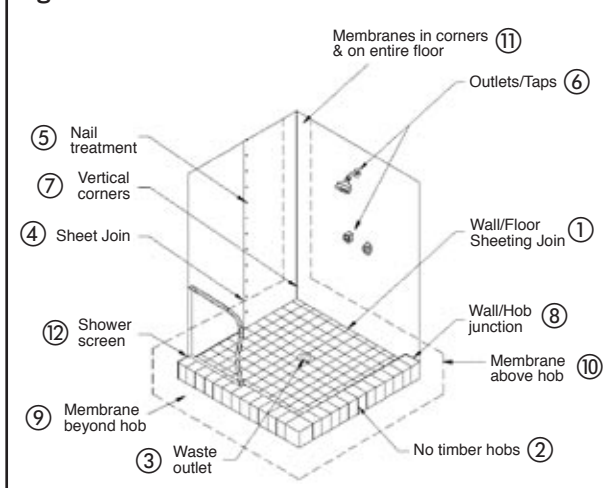
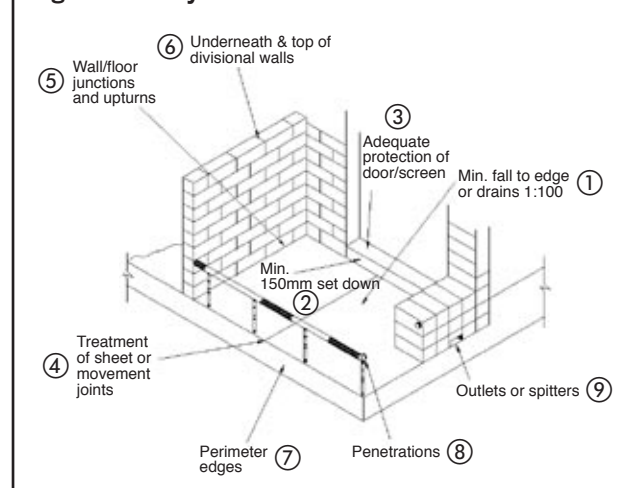

Fig.2 - Balcony - Critical Areas



## APPLICATION NOTES

### Surface preparation

- Ensure all surfaces are structurally sound and totally dry. The pores of concrete surfaces should be open (absorbent surface). All sheet substrates must be securely fixed in accordance with the manufacturers instructions
- Falls to outlets of at least 1:60 or approx. 30mm in 2m (wet areas) or 1:100 externally, must be achieved prior to tiling
- The surface to be coated should be free from dust, oil, paint, curing compounds and any other contaminating materials
- Damaged concrete should be repaired (leveled) and surface defects including all cracks and sharp protrusions should be treated prior to the application of the membrane
- Remove laitance on concrete or screeds by mechanical means
- Highly dense (>40MPa) or steel trowelled concrete should be roughened by suitable mechanical means (shot blasting, grinding, etc)

### Priming

The primer is a critical part of the waterproofing system. Apply one coat of Ardex Superflex Primer by brush or roller to all areas to be waterproofed including the floor waste. Allow the primer to be completely dry prior to the application of the Ardex WPM 001 (Superflex Premixed) membrane. This will take around 20-30 minutes depending upon weather conditions and porosity of the substrate. Coverage is approximately 6m<sup>2</sup> per litre. Plastic (eg. PVC) pipes should be primed with a solvent based plumbers pink primer. Prime metal surfaces with a suitable metal primer such as epoxy polyamide primer.

## GENERAL APPLICATION

### Crack preparation

#### Cracks <2mm:

Clean and remove any loose particles in the crack. Prime the crack and adjacent area carefully with Ardex Superflex Primer and allow to dry before applying two coats of Ardex WPM 001 (Superflex Premixed) membrane, in a band at least 200mm wide equidistantly across the crack, along the length of the crack.

#### Cracks 2-6mm: (Refer Fig.3)

Prepare and prime the crack as above. Apply a bead of neutral cure silicone into the crack and extend it 5mm either side. Apply a 300mm wide band of Ardex WPM 001 (Superflex Premixed) equidistantly across the crack along the entire length of the crack. Place a 190mm wide band of Ardex "Deckweb" polyester woven cloth reinforcement over the applied membrane. Thoroughly wet out the cloth and remove all creases in, or air

pockets under the mat. Immediately apply a second coat to completely fill the mat.

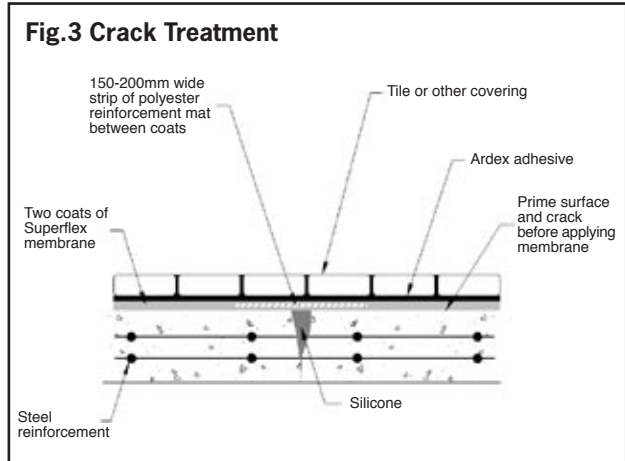

#### Cracks >6mm:

Contact your local Ardex representative.

#### Movement/construction joints (Refer Fig.4)

##### Movement joints (<6mm)

Clean and prime the joint before filling it with a bead of neutral cure silicone and extending it 5mm each side of joint. Apply a 300mm wide band of Ardex WPM 001 (Superflex Premixed) equidistantly across the crack along the entire length of the crack. Place a 190mm wide band of Ardex "Deckweb" polyester woven cloth reinforcement over the applied membrane. Thoroughly wet out the cloth and remove all creases in, or air pockets under the mat. Immediately apply a second coat to completely fill the mat.

##### Construction joints (>6mm)

Use the same procedure as above, but replace the reinforcing mat with the Ardex Joint Bridging Band. Note: if tiling, movement joints should be taken to the surface of the tiles. Fill the joints between the tiles immediately above the movement joints with an appropriate joint sealant.

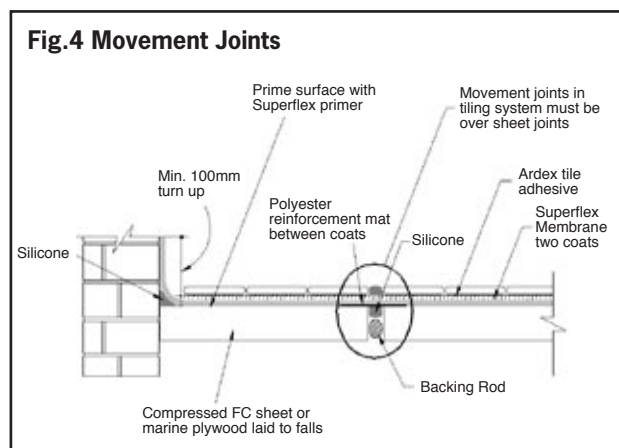

# ARDEX WPM 001

## Superflex Bathroom & Balcony Premixed - 1 Part Undertile Waterproofing Membrane

### Corners & covering areas (Refer Fig.5)

After priming with Ardex Superflex Primer and allowing to dry, apply a generous bead (10mm) of neutral cured silicone sealant in coving areas and corners. Smooth over the silicone so that it extends 5mm up the wall and 5mm over the floor and allow to touch dry.

Apply a first coat of Ardex WPM 001 (Superflex Premixed) to the area and allow the membrane to dry.

Apply a second coat ensuring that excess product is removed from the junction (the final dry film thickness should be around 1.2mm) Alternatively, if a polyester reinforcement mat is used between coats then the second coat can be applied as soon as the mat is fully bedded into the first coat.

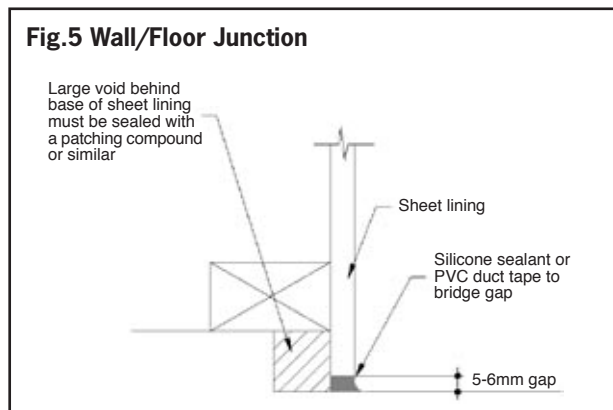

### WALL/FLOOR JUNCTION

After priming with Ardex Superflex Primer and allowing to dry, apply a 300mm wide band of Ardex WPM 001 (Superflex Premixed) equidistantly across the crack along the entire length of the crack. Place a 190mm wide band of Ardex "Deckweb" polyester woven cloth reinforcement over the applied membrane. Thoroughly wet out the cloth and remove all creases in, or air pockets under the mat. Immediately apply a second coat to completely fill the mat. The Ardex WPM 001 (Superflex Premixed) should be applied to at least 100mm up the wall surfaces as per the recommendations for the application of Ardex WPM 001 (Superflex Premixed) to floors.

### Walls

Two coats of Ardex WPM 001 (Superflex Premixed) are required to achieve a minimum total dry film thickness of 0.5mm.

After priming with Ardex WPM 265 (Sheltercoat Water Based Primer) and allowing to dry, apply two coats of Ardex Superflex Premixed Bathroom & Balcony (to achieve a minimum dry film thickness of 0.5mm) in two opposite directions. Wall sheets joints should be treated with a neutral cure silicone, PVC duct tape or base jointing compound. In balcony situations take the membrane up underneath any existing cover flashing or install appropriate flashing. Allow the first coat to dry

before applying the second coat.

### Floors

Two coats of Ardex WPM 001 (Superflex Premixed) are required to achieve a minimum total dry film thickness of 1.0mm. The flooring recommendations should be extended at least 150mm up all perimeter walls.

Prime the surface with Ardex Superflex Primer and allow to dry.

Apply the first coat over the primed surface and allow it to dry (1-2 hours at 23°C, 50% RH) before applying a second coat in an opposite direction. In shower recesses a drainage flange must be installed on all timber/sheeted floors, and are strongly recommended on all other substrates. Where possible rebate the flange into the floor. Seal the perimeter of the flange with neutral cure silicone treatment. If a flange is not installed the membrane must be applied down into the pipe. (Refer Fig.6) Allow the membrane to dry completely before tiling. Refer drying times above.

### Waste outlet (Refer Fig.6)

Prime the surface with Ardex Superflex Primer and allow to dry.

Apply Ardex WPM 001 (Superflex Premixed) over the adjacent floor surface extending down into the waste outlet pipe overlapping the pipe surfaces by at least 30mm. Place Ardex "Deckweb" polyester woven cloth reinforcement over the applied membrane. Thoroughly wet out the cloth and remove all creases in, or air pockets under the mat. Immediately apply a second coat to completely fill the mat.

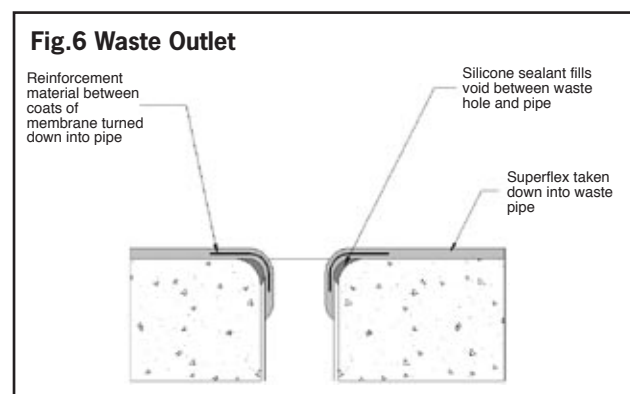

### Balcony penetrations (Refer Fig.7)

Place a suitable flanged metal upstand around the penetration.

Prime the metal with an appropriate metal primer such as an epoxy polyamide primer and allow to dry. Apply a 10mm bead of neutral cure silicone around the perimeter of the penetration. Apply the first coat of Ardex WPM 001 (Superflex Premixed) on the substrate and the flanged metal.

Allow first coat to dry before applying a second coat ensuring a finished dry film thickness of no less than

1.0mm is achieved. Place a suitable flashing collar around the penetration sealing it with a suitable sealant.

### Tiling systems

It is advisable to conduct a flood test of the shower once the membrane has cured (normally after 48 hours), and before the tiling commences. A broad range of Ardex tile adhesives can be used over Ardex Superflex membranes. Contact Ardex or your nearest ABA merchant for advice on the most suitable system.

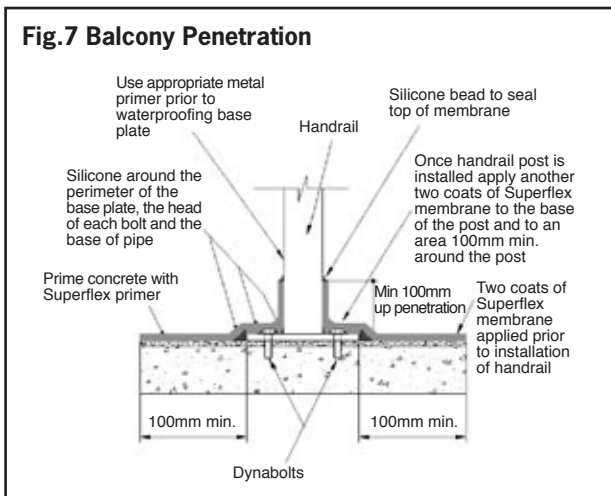

### TECHNICAL DATA

#### Ardex Superflex Premixed Characteristics of liquid

Form & Colour	Blue viscous paste
Type	Single part
Specific Gravity	Approx. 1.34kg/litre
pH of Liquid	9.0
Viscosity of Liquid (RVT Brookfield, spindle 7 speed 10)	52,000cps
Non Volatile Matter (volume) AS1321.10	50.3%±1
Water Absorption AS A121	7.8%
Tensile Strength 28 days dry AS1145	1.91 MPa
After UV exposure AS2433	2.86 MPa
Elongation at Break 28 days dry AS1145	207%
After UV exposure AS2433	167%

NOTE: Most of the tests have been carried out in the Ardex laboratory under standard conditions (23±2°C, 50±5% RH)





---

# ARDEX WPM 002

## **Superflex Bathroom & Balcony - 2 Part**

---

2 Part Undertile Waterproofing Membrane  
BRANZ Appraised

# ARDEX WPM 002

## Superflex Bathroom & Balcony - 2 Part 2 Part Undertile Waterproofing Membrane

### BRANZ APPRAISED

BRANZ Appraisal Certificates No 472 (2005) and No 473 (2005) have been issued. Separate copies available on request.



### PRODUCT DESCRIPTION

Ardex WPM 002 (Superflex 2 Part) is a tough, ready to use waterproofing membrane specifically designed for use under tiles. Ardex WPM 002 (Superflex 2 Part) is a fast drying two component waterproofing membrane specifically designed for use under tiles. The products have been uniquely formulated with synthetic microfibres to increase its strength and eliminate the need for a separate reinforcement mat. Ardex WPM 002 (Superflex 2 Part) are based on the most advanced acrylic polymer technology, and is totally resistant to re-emulsification. Ardex WPM 002 (Superflex 2 Part) is flexible, safe to use, low in odour, and is fully compatible with polymer modified tile adhesives.

Ardex WPM 002 (Superflex 2 Part) is one of the fastest drying one part acrylic membranes on the market - normally ready to tile in 48 hours @ 23°C.

### FEATURES/BENEFITS

Fast drying Ardex WPM 002 (Superflex 2 Part) can be tiled over in 48 hours. Ardex WPM 002 (Superflex 2 Part) can be tiled over in 4 hours @ 23°C, 50% RH in non critical areas\*.

Features Benefits

- Liquid reinforced: Excellent strength, eliminates need for reinforcing mat.
- Flexible: Accommodates normal building movement.
- Advanced acrylic: Will not re-emulsify polymers.
- Designed for tiling - Fully compatible with ABA tile systems adhesives.
- Water based, safe to use, low odour & easy cleaning. BRANZ/CSIRO Appraisals Approved for undertile waterproofing in shower recesses by independent testing authority.

#### CSIRO Appraisal #208

\*Critical areas include areas where the membrane is applied at greater than 0.5mm or over impermeable substances such as over bond breakers or incorporating other reinforcement. Longer drying times are necessary in these areas.

### APPLICATION RANGE

#### Performance

Levels Commercial and residential.

#### Location

Internal wet areas, balconies, decks, and other areas

that will be tiled or otherwise protected from regular foot traffic.

#### Surfaces

Walls & floors.

#### Substrates

##### Concrete

Cured for min. 28 days or sealed when set with one coat. Ardex Ardex HydrEpoxy 300 at a coverage rate of 3.0 square metres per litre and allowed to cure overnight. Wet concrete should be allowed to dry thoroughly or sealed with one coat of Ardex Ardex HydrEpoxy 300 as above.

##### Renders and Screeds

Cured for min. 7 days or sealed when set with one coat Ardex HydrEpoxy 300 at a coverage rate of 3.0 square metres per litre and allowed to cure overnight. Wet render should be allowed to dry thoroughly or sealed with one coat of Ardex Ardex HydrEpoxy 300 as above.

##### Fibre cement

Suitable for wet area grade fibre cement.

##### Plasterboard

Wet area grade only.

##### Plywood

Structural plywood (PAA branded) or marine grade (Internal use only).

##### Particleboard

Wet area grade, internal use only (special preparation is required - contact Ardex).

##### Permanent immersion

Ardex WPM 002 (Superflex 2 Part) is suitable.

In conditions of permanent immersion when used as an undertile membrane.

Contact Ardex for use over existing membranes, covering materials, and any other substrates not listed.

### SPECIFICATION CLAUSE

Ardex WPM 002 (Superflex 2 Part).

The waterproofing membrane shall be Ardex Superflex Two Part Bathroom & Balcony: a two component cementitious acrylic modified fibre reinforced membrane formulated to provide a tough, long lasting water barrier under tiling systems.

### PACKAGING

Two component: 20kg liquid pail/2 x 10kg bags powder

### SHELF LIFE

12 months when stored in the original unopened packaging, in a dry place at 23°C. Do not store in direct sunlight. Replace lid tightly after use. Use remaining

contents from part used containers within 3 months.

## COVERAGE

Two coats are recommended for an effective waterproof membrane.

Coverage will vary depending on the porosity of the surface.

One 40kg unit will cover approximately 18-20m<sup>2</sup> (based on two coats) depending on area requirements between wall and floor surfaces to be treated.

## DRYING TIMES

### Recoat time

1-2 hours (23°C, 50% RH) at between first and second coats. Alternatively, if a polyester mat is used between coats then the second coat can be applied whilst the first coat is still wet.

### Dry through

The slowest drying areas are those where the membrane has been applied over a silicone bond breaker, eg. wall and floor junctions. The membrane cannot be tiled over until these critical areas are completely dry.

Ardex WPM 002 (Superflex 2 Part) membrane is totally dry in 24 hours at 23°C, 50% RH but can take up to 48 hours at 10°C / 50% RH in corners or for thick films..

In areas where bond breakers or additional reinforcement are not used the Ardex WPM 002 (Superflex 2 Part) can be tiled over after 4 hours at 23°C, 50% RH.

### Fully cured

The shower should not be used until the membrane has reached its full strength. The Ardex WPM 002 (Superflex 2 Part) membranes are fully cured after 3 days at 23°C, or after 5 days at 10°C.

Drying times will vary depending on humidity, surface temperature and surface porosity.

Do not apply on substrates where the surface temperature is below 10°C or above 35°C.

## CLEANING

Wash hands, brushes, rollers, etc, with water while the membrane is still fresh. Remove cured material with mineral turpentine.

## PRECAUTIONS

Do not use the product in the following situations:

- Areas subject to negative hydrostatic pressure or rising damp
- Where the substrate is wet - wet surfaces can be sealed with one coat Abaseal at a coverage rate

of 3.0 square metres per litre and allowed to cure overnight.

- Where rain is imminent
- Where the membrane will be left exposed and subjected to regular foot traffic
- On glazed, glass or other totally impervious surfaces (eg. areas pre-treated with water repellants)
- Where the surface temperature is below 10°C or greater than 35°C
- All floor areas must have adequate falls either built into the substrate or achieved with a sand/cement screed prior to application of the Ardex WPM 002 (Superflex 2 Part).

For substrates or situations other than those listed contact Ardex.

## SAFETY DATA

Ardex WPM 002 (Superflex 2 Part) is non-toxic. However, the contents should not be swallowed or inhaled. In case of eye contamination, rinse thoroughly with clean water. If irritation continues seek medical advice.

Material Safety Data sheets are available from Ardex upon request.

## QUALITY PRODUCT

Ardex WPM 002 (Superflex 2 Part) is manufactured and tested to Ardex procedures which are maintained in accordance with Quality System Standard ISO 9001.

## USER NOTES

The technical details and recommendations contained in this data sheet are given in good faith and represent the best of our knowledge and experience at the time of printing. It is the responsibility of the user to ensure that the product is used in accordance with Ardex instructions and in applications for which they are intended.

## APPLICATION

Apply Ardex WPM 002 (Superflex 2 Part) by brush or roller. A medium nap (8-12mm pile) paint roller is recommended. New rollers should be dampened with water before being used for the first time.

For best results with a paint brush use a good quality, 50mm long bristle variety.

To achieve the required dry film thickness per coat application must consist of laying the product onto the surface and light finish the surface. Do not try to apply in the same manner as a building paint. A conventional building paint is normally applied at 25-40 microns for wet film thickness while Ardex WPM 002 (Superflex 2 Part) needs to be applied at between 0.8 and 1.2mm per coat depending on product and application.

# ARDEX WPM 002

## Superflex Bathroom & Balcony - 2 Part 2 Part Undertile Waterproofing Membrane

### CRITICAL AREAS

#### Internal wet areas (Refer Fig.1)

1. Construction should be in accordance with Australian/New Zealand Standard 3740-2004.
2. All render and tile bed requirements should be completed before application of the membrane and tiles or other floor coverings should be direct bonded to the membrane.
3. Ensure wall & floor sheets are installed as per sheet manufacturer's recommendations.
4. Ensure suitable brick/concrete hobs are used (do not use timber), and that the top of the hob does not slope outwards.
5. Ensure that falls to the waste are min 1:60 (ie. approx. 30mm in 2m) before waterproofing. Ensure outlet pipes are fixed securely and that the waste or drainage flanges are recessed into the floor.
6. Avoid sheet joints in shower recess floor. Ensure that sheets are securely fixed to the wall at the bottom edge, and sheet joints are sealed with a neutral cured silicone sealant spread approximately 5mm on either side of the joint.
7. Treat nail and screw holes with neutral cure silicone sealant.
8. Seal the perimeters of taps, shower outlets and waste outlets with neutral cure silicone sealant.
9. Apply a bead of neutral cure silicone sealant to all horizontal and vertical corners.
10. Apply a bead of neutral cure silicone sealant to the junction of the hob or angle and walls.
11. Apply the membrane to the entire shower recess floor and down into waste or drainage flange. Apply the membrane over the hob and at least 100mm beyond the outside edge of the hob (ideally to entire wet area floor).
12. Apply the membrane 1800mm up the walls or to

the height of the shower rose within the shower recess.

13. Install the shower screen to inside edge of the hob.

#### Balconies and decks (Refer Fig.2)

1. Ensure that the deck is constructed with falls to edge/drains of min 1:100 (ie. 20mm in 2m) or else achieve the fall with a sand/cement screed.
2. Ensure a min set down (step down) of 150mm to the finished floor level (ie. top of tiles).
3. Ensure suitable flashing is installed, ideally prior to the installation of the balcony screen/sliding door.
4. Treat any sheet joints with a neutral cure silicone prior to waterproofing.
5. Prepare and seal all wall/floor junctions with a bead of neutral cure silicone.
6. Apply the membrane up the step down and as far up underneath the screen door flashing as possible (ideally waterproof prior to installing door).
7. Where possible, apply the membrane prior to building divisional walls.
8. Apply the membrane to the entire balcony floor and at least 50mm up the wall above the top surface of the finished tiles and finished below the wall drainage vents.
9. Apply the membrane to the top of the parapets and divisional walls and install suitable metal capping.
10. Apply the membrane down over the front edge of the balcony onto the drip rail.
11. Carefully seal any gaps around balcony penetrations prior to applying the membrane.
12. Apply the membrane down into outlets and drains, ensuring excess material is removed.
13. Ensure all weep holes are above the membrane application area.

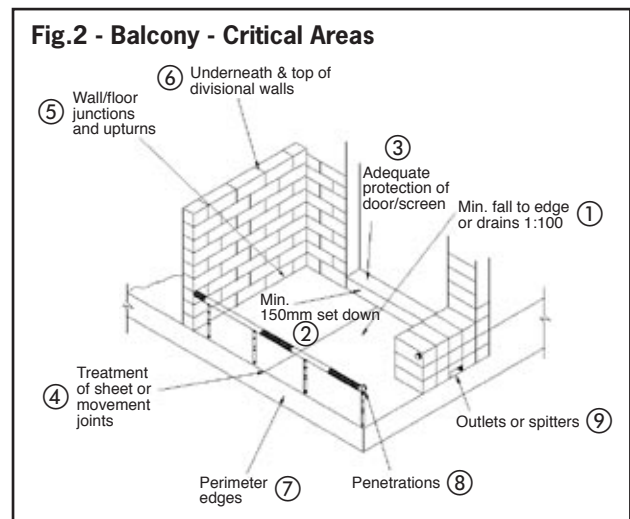
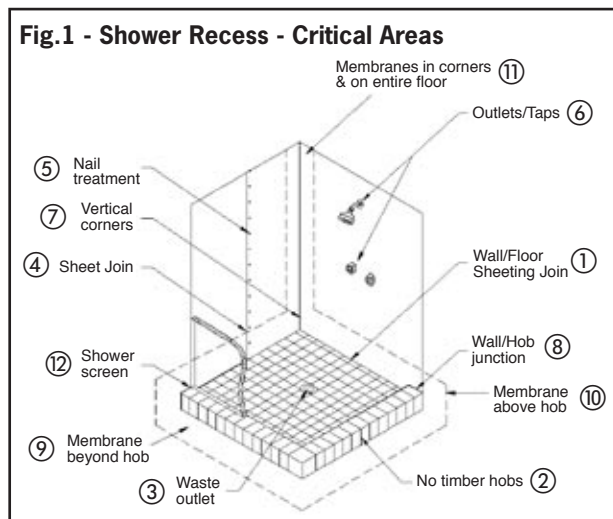

## APPLICATION NOTES

### Surface preparation

- Ensure all surfaces are structurally sound and totally dry. The pores of concrete surfaces should be open (absorbent surface). All sheet substrates must be securely fixed in accordance with the manufacturers instructions.
- Falls to outlets of at least 1:60 or approx. 30mm in 2m (wet areas) or 1:100 externally, must be achieved prior to tiling.
- The surface to be coated should be free from dust, oil, paint, curing compounds and any other contaminating materials.
- Damaged concrete should be repaired (leveled) and surface defects including all cracks and sharp protrusions should be treated prior to the application of the membrane.
- Remove laitance on concrete or screeds by mechanical means.
- Highly dense (>40MPa) or steel trowelled concrete should be roughened by suitable mechanical means (shot blasting, grinding, etc).

### Priming

The primer is a critical part of the waterproofing system. Apply one coat of Ardex Superflex Primer by brush or roller to all areas to be waterproofed including the floor waste. Allow the primer to be completely dry prior to the application of the Ardex WPM 002 (Superflex 2 Part) membrane. This will take around 20-30 minutes depending upon weather conditions and porosity of the substrate. Coverage is approximately 6m<sup>2</sup> per litre. Plastic (eg. PVC) pipes should be primed with a solvent based plumbers pink primer. Prime metal surfaces with a suitable metal primer such as epoxy polyamide primer.

## GENERAL APPLICATION

### Crack preparation

#### Cracks <2mm:

Clean and remove any loose particles in the crack. Prime the crack and adjacent area carefully with Ardex Superflex Primer and allow to dry before applying two coats of Ardex WPM 002 (Superflex 2 Part) membrane, in a band at least 200mm wide equidistantly across the crack, along the length of the crack.

#### Cracks 2-6mm: (Refer Fig.3)

Prepare and prime the crack as opposite. Apply a bead of neutral cure silicone into the crack and extend it 5mm either side. Apply a 300mm wide band of Ardex WPM 002 (Superflex 2 Part) equidistantly across the crack along the entire length of the crack. Place a 190mm wide band of Ardex "Deckweb" polyester woven cloth reinforcement over the applied membrane. Thoroughly wet out the cloth and remove all creases

in, or air pockets under the mat. Immediately apply a second coat to completely fill the mat.

#### Cracks >6mm:

Contact your local Ardex representative.

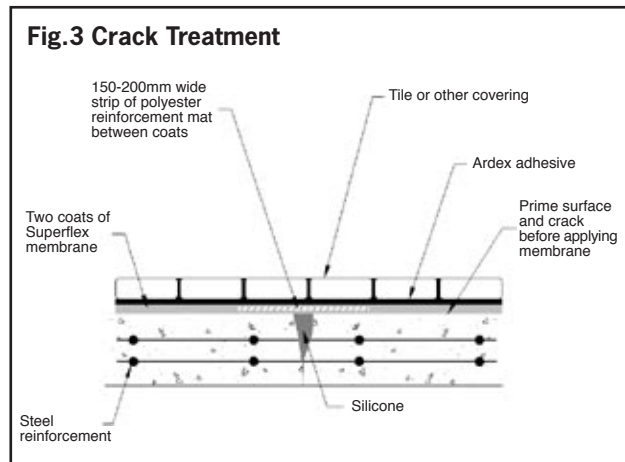

### Movement/construction joints (Refer Fig.4)

#### Movement joints (<6mm)

Clean and prime the joint before filling it with a bead of neutral cure silicone and extending it 5mm each side of joint. Apply a 300mm wide band of Ardex WPM 002 (Superflex 2 Part) equidistantly across the crack along the entire length of the crack. Place a 190mm wide band of Ardex "Deckweb" polyester woven cloth reinforcement over the applied membrane. Thoroughly wet out the cloth and remove all creases in, or air pockets under the mat. Immediately apply a second coat to completely fill the mat.

#### Construction joints (>6mm)

Use the same procedure as above, but replace the reinforcing mat with the Ardex Joint Bridging Band. Note: if tiling, movement joints should be taken to the surface of the tiles. Fill the joints between the tiles immediately above the movement joints with an appropriate joint sealant.

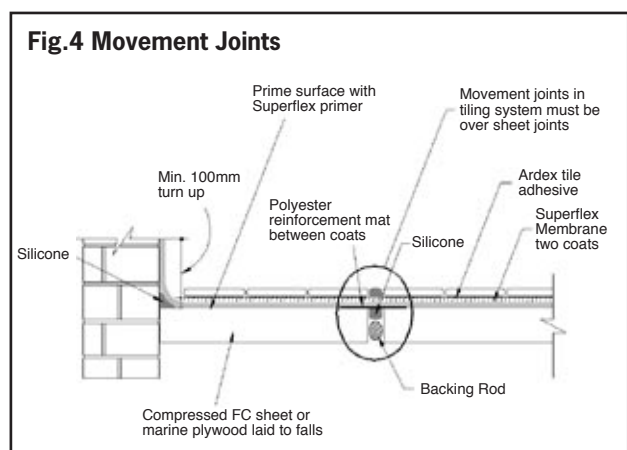

# ARDEX WPM 002

## Superflex Bathroom & Balcony - 2 Part 2 Part Undertile Waterproofing Membrane

### Corners & covering areas (Refer Fig.5)

After priming with Ardex Superflex Primer and allowing to dry, apply a generous bead (10mm) of neutral cured silicone sealant in coving areas and corners. Smooth over the silicone so that it extends 5mm up the wall and 5mm over the floor and allow to touch dry.

Apply a first coat of Ardex WPM 002 (Superflex 2 Part) to the area and allow the membrane to dry.

Apply a second coat ensuring that excess product is removed from the junction (the final dry film thickness should be around 1.2mm) Alternatively, if a polyester reinforcement mat is used between coats then the second coat can be applied as soon as the mat is fully bedded into the first coat.

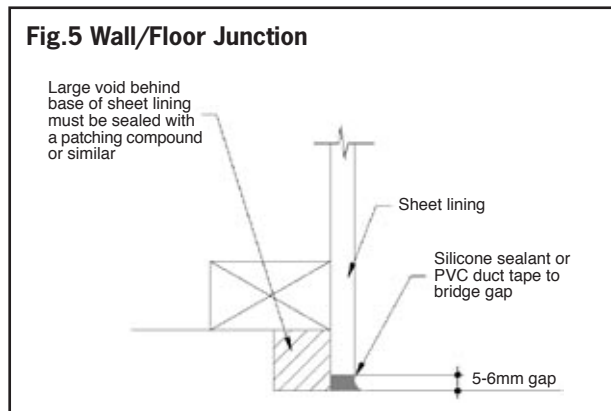

### WALL/FLOOR JUNCTION

After priming with Ardex Superflex Primer and allowing to dry, apply a 300mm wide band of Ardex WPM 002 (Superflex 2 Part) equidistantly across the crack along the entire length of the crack. Place a 190mm wide band of Ardex "Deckweb" polyester woven cloth reinforcement over the applied membrane. Thoroughly wet out the cloth and remove all creases in, or air pockets under the mat. Immediately apply a second coat to completely fill the mat. The Ardex WPM 002 (Superflex 2 Part) should be applied to at least 100mm up the wall surfaces as per the recommendations for the application of Ardex WPM 002 (Superflex 2 Part) to floors.

### Walls

Two coats of Ardex WPM 002 (Superflex 2 Part) are required to achieve a minimum total dry film thickness of 0.5mm.

After priming with Ardex Superflex Primer and allowing to dry, apply two coats of Ardex Superflex 2 Part Bathroom & Balcony (to achieve a minimum dry film thickness of 0.5mm) in two opposite directions. Wall sheets joints should be treated with a neutral cure silicone, PVC duct tape or base jointing compound. In balcony situations take the membrane up underneath any existing cover flashing or install appropriate

flashing. Allow the first coat to dry before applying the second coat.

### Floors

Two coats of Ardex WPM 002 (Superflex 2 Part) are required to achieve a minimum total dry film thickness of 1.2mm. The flooring recommendations should be extended at least 100mm up all perimeter walls.

Prime the surface with Ardex Superflex Primer and allow to dry.

Apply the first coat over the primed surface and allow it to dry (1-2 hours at 23°C, 50% RH) before applying a second coat in an opposite direction. In shower recesses a drainage flange must be installed on all timber/sheeted floors, and are strongly recommended on all other substrates. Where possible rebate the flange into the floor. Seal the perimeter of the flange with neutral cure silicone treatment. If a flange is not installed the membrane must be applied down into the pipe. (Refer Fig.6) Allow the membrane to dry completely before tiling. Refer drying times above.

### Waste outlet (Refer Fig.6)

Prime the surface with Ardex Superflex Primer and allow to dry.

Apply Ardex WPM 002 (Superflex 2 Part) over the adjacent floor surface extending down into the waste outlet pipe overlapping the pipe surfaces by at least 30mm. Place Ardex "Deckweb" polyester woven cloth reinforcement over the applied membrane. Thoroughly wet out the cloth and remove all creases in, or air pockets under the mat. Immediately apply a second coat to completely fill the mat.

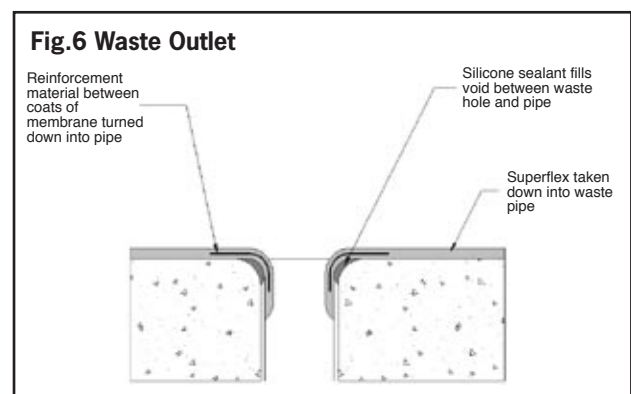

### Balcony penetrations (Refer Fig.7)

Place a suitable flanged metal upstand around the penetration.

Prime the metal with an appropriate metal primer such as an epoxy polyamide primer and allow to dry. Apply a 10mm bead of neutral cure silicone around the perimeter of the penetration. Apply the first coat of Ardex WPM 002 (Superflex 2 Part) on the substrate and the flanged metal.

Allow first coat to dry before applying a second coat ensuring a finished dry film thickness of no less than 1.0mm is achieved. Place a suitable flashing collar around the penetration sealing it with a suitable sealant.

### Tiling systems

It is advisable to conduct a flood test of the shower once the membrane has cured (normally after 48 hours), and before the tiling commences. A broad range of Ardex tile adhesives can be used over Ardex Superflex membranes. Contact Ardex or your nearest ABA merchant for advice on the most suitable system.

### TECHNICAL DATA

#### Ardex Superflex 2 Part

Characteristics of components

Form & Colour	Liquid: white, medium viscosity Powder: off white
---------------	--

Characteristics of mixed product

Mixing Ratio	1:1 by weight
SG of mixed product	1.44kg/litre
Non Volatile Matter	77±1%
Colour	light grey/green

Characteristics of cured membrane

Shore A hardness ASTM D2240	
- dry film	85 - 90
- wet film	75 - 80
Water Absorption	
AS A121 App K	4.3%
Tensile Strength	
28 days dry AS1145	1.8 MPa
Elongation at Break	
28 days dry AS1145	>200%

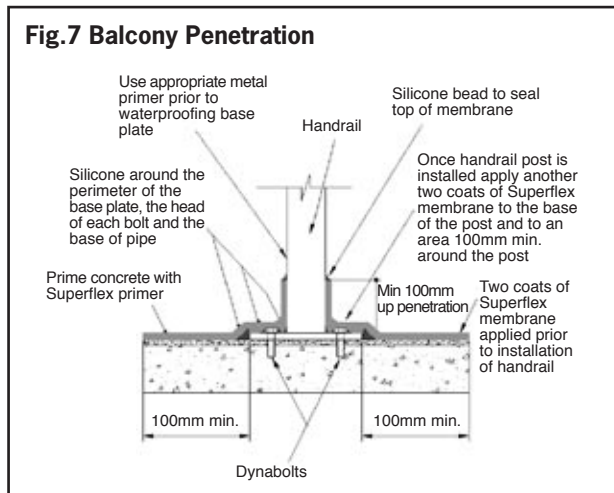

NOTE: Most of the tests have been carried out in the Ardex laboratory under standard conditions (23±2°C, 50±5% RH)





---

# ARDEX WPM 390

## Undertile PU Membrane

---

Modified Polyurethane Waterproof Membrane

# ARDEX WPM 390

## Undertile PU Membrane

## Modified Polyurethane Waterproof Membrane

### DESCRIPTION

Ardex WPM 390 (Undertile PU) is a water-based polyurethane-acrylic waterproofing membrane developed for high performance under-tile waterproofing.

- Tough flexible film
- UV stable when left exposed
- Long shelf life
- Environmentally friendly - solvent free - suitable for confined areas
- Can be tiled over- good adhesion with Ardex tile adhesives
- Excellent adhesion to a wide range of substrates
- Fast drying

### RANGE OF APPLICATION

For commercial and residential internal/external wet areas, balconies, decks and other areas that will be tiled or otherwise protected from regular foot traffic.

### SUBSTRATES

#### Concrete

Cured for minimum 28 days, wet concrete should be allowed to dry thoroughly or sealed with one coat of Ardex WPM 300 (HydrEpoxy 300) at coverage rate of 3m<sup>2</sup> per litre.

#### Renderers and screeds

Cured for min 7 days. Wet render should be allowed to dry thoroughly or sealed with one coat of Hydrepoxy 300 at coverage rate of 3m<sup>2</sup> per litre and allowed to cure overnight.

#### Fibre cement sheets

Wet area grades only.

#### Plasterboard

Wet area grades only.

#### Plywood

Structural plywood (PAA branded) or marine grade.

### PRIMERS

Ardex WPM 390 (Undertile PU) is suitable to use over Ardex WPM 300 (HydrEpoxy 300), Ardex Sheltercoat or Superflex Solvent or Water based primer or Ardex Multiprime.

### APPLICATION

Ardex WPM 390 (Undertile PU) should be thoroughly mixed to a uniform mix and ensure the coating is applied evenly at recommended coverage rates. Mobile joints should be reinforced using Deckweb and the membrane must be lapped to intrusions such as waste outlets in accordance with the instructions. Apply Ardex WPM 390 (Undertile PU) by brush or roller. A medium nap (8-12mm pile) or 50mm long bristle paint brush is recommended.

### COVERAGE

This will vary with the porosity of the substrates. Two coats are recommended to get optimum performance.

#### For floors

A dry film thickness of 1.0mm is required. A 20kg unit (15 litres) will cover approximately 8m<sup>2</sup> (based on two coats)

#### For walls

A dry film thickness of 0.5 mm is required. A 20kg unit (15 litres) will cover approximately 16m<sup>2</sup>.

### DRYING TIME

Recoat time is 1-2 hours in between first and second coats. Drying time on flat surfaces under standard conditions is 4 hours. However, dry through time will be slowest in areas where Ardex WPM 390 (Undertile PU) is applied over silicone bond breaker. Make sure these areas are dry before tiling. In some cases, this can vary from 24 hours to 48 hours.

Full cure of the product is 3 days after application at 23°C. Drying times will vary depending on humidity, surface temperature and porosity of substrates.

### PACKAGING

20 kgs (approximately 15 litres)

### SHELF LIFE

12 months when stored in the original unopened packaging in a dry place at 23°C.

### CLEANING

Wash hands, brushes, rollers with water while product is still fresh. For cured material, use mineral turpentine.

## PRECAUTIONS

All surfaces must be structurally sound, dry and free from all surface contaminants.

Do not use Ardex WPM 390 (Undertile PU) under the following conditions:

- Areas subject to negative hydrostatic pressure or rising damp
- Wet substrates - need to be sealed with one coat Ardex WPM 300 (HydrEpoxy 300) as described earlier
- Surface temperature is below 10°C or greater than 35°C

## SAFETY DATA

Ardex WPM 390 (Undertile PU) is non-toxic. However contents should not be swallowed or inhaled. In case of eye contamination, rinse thoroughly with clean water. If irritation continues, seek medical advice. MSDS sheets are available from Ardex upon request.

## QUALITY PRODUCT

Ardex WPM 390 (Undertile PU) is manufactured and tested to Ardex procedures which are maintained in accordance with Quality System Standard ISO 9001.

## TECHNICAL DATA

### Properties of Liquid Material

Appearance	Mauve Paste
Viscosity	(6/20/25°C)
AS 1580:1990	40,000 cps
Density (kg/L)	
AS 4459:1999	1.36
Solids, by mass	
AS1580:1992	63-67%
Volume solids	
AS1580-	52.5%
Properties of the Cured Membrane	
Tensile Strength	
MPa AS 1145	4.08 MPa
% Elongation	300
Shore A Hardness	70-80
After 14 days UV Exposure (AS 1145/2433)	
Tensile Strength	
AS 1145	4.50 MPa
% Elongation	307
Shore A Hardness	80-90





---

# ARDEX WPM 310

## Shelterguard

---

External Facade & Roof Membrane

# ARDEX WPM 310

## Shelterguard

### External Facade & Roof Membrane

#### PRODUCT DESCRIPTION

Ardex WPM 310 (Shelterguard) is a tough, UV stable flexible premixed liquid applied waterproofing membrane. It has been specifically formulated as a general purpose membrane for exposed wall and roof waterproofing. Ardex WPM 310 (Shelterguard) can be applied as an aesthetically attractive textured or semi-smooth finish for walls or a semi-smooth uniform finish for roofs. Ardex WPM 310 (Shelterguard) is available in a range of standard colours.

#### FEATURES/BENEFITS

- Flexible - Accommodates normal building movement
- Provides excellent UV resistance and long term protection from elements
- Excellent workability - Easy, quick to apply
- Decorative - Choice of colours
- Water based - Safe to use, low odour and easy cleaning

#### TYPICAL USES

- **At a dry film thickness of 0.35mm** the film formed is classified as semi-permeable and suitable for substrates that have to breathe or a semi-permeable membrane.

As a decorative textured finish and waterproofing of external walls and facades.

- **At a dry film thickness of 1.0mm** the film forms a waterproof membrane.

As a waterproof membrane over concrete roofs, decks. Suitable for light (service) traffic when fully reinforced and overcoated with Sheltercoat Protective Finish. High traffic areas will require a protective cement screed over the membrane.

#### LIMITATIONS

Do not use the product in the following situations:

- Areas subject to traffic must be treated as follows:-
  - Light (service) traffic - fully reinforce with Ardex Deckweb and overcoat with Ardex WPM 355 (Sheltercoat Protective Finish).
  - Medium or Heavy traffic - apply a protective cementitious screed over the membrane to provide protection.
- Where solvent or petroleum based products could be spilled
- Do not use the product under the following application conditions
- When rain appears imminent
- Where solvent or petroleum based products could be spilled

- Where the surface temperature is below 10° or greater than 35°C
- On wet surfaces that have not been sealed with Ardex WPM 300 (HydrEpoxy 300).
- Do not attempt to thin down the mix with water, cement etc For substrates or situations other than those listed, contact your Ardex representative.

#### SURFACE PREPARATION

Ensure all surfaces are structurally sound or securely fixed and totally dry. The surface to be coated should be free from dust, oil, curing compounds and any other contaminating materials. When applying over existing coatings, ensure they are firmly bonded. Damaged or spalled concrete should be repaired (leveled) and surface defects including all cracks and sharp protrusions should be treated prior to the application of the membrane. Remove laitance by mechanical means and dense concrete should be mechanically roughened to open the pores of the concrete. New concrete should be left at least 21 days to cure or primed with Ardex WPM 300 (HydrEpoxy 300). Wet, damp or new concrete substrate surfaces should be primed with Ardex WPM 300 (HydrEpoxy 300) at 3.0 square metres per litre (0.3mm wet film thickness) and allowed to cure overnight.

All surfaces, other than those sealed with Ardex WPM 300 (HydrEpoxy 300), must be primed with Ardex WPM 270 (Sheltercoat Solvent Based Primer) or Ardex WPM 265 (Sheltercoat Water Based Primer) at a coverage rate of 6 square metres per litre. Ardex WPM 270 (Sheltercoat Solvent Based Primer) is preferred for use in external applications. Hebel block or other highly porous surfaces may need two coats.

Allow the primer to dry for at least 30 minutes before applying the first coat of membrane. The primer should preferably be overcoated within the same day of application to avoid intercoat contamination.

#### APPLICATION

##### EXTERNAL WALL MEMBRANE APPLICATION

Apply using a nap or textured roller. Apply the coating in two coats ensuring a uniform coverage is achieved at an approximate wet film thickness of 0.3mm per coat to achieve an overall dry film thickness of 0.3mm. Allow the first coat to become hard dry (normally about 4 hours at 23°C, 50% RH) before applying the second coat.

##### ROOF MEMBRANE APPLICATION

Apply the coating in two coats ensuring a uniform coverage is achieved at an approximate wet film thickness of 1.0mm per coat to achieve an overall dry film thickness of 1.0mm. Allow the first coat to become hard dry (normally about 4 hours at 23°C, 50% RH)

before applying the second coat.

Cold joints and mobile joints must incorporate a bond breaker and be reinforced using Ardex Deckweb. Areas subject to light (service) traffic should be fully reinforced using Ardex Deckweb and overcoated with Ardex WPM 355 (Sheltercoat Protective Finish). Areas subject to heavy traffic should have a protective cementitious screed applied over the membrane.

### Surface Finish

The surface finish achieved can be varied by selection of method of application. Prior to the commencement of any project it is recommended that a sample of the

Surface Finish Profile	Roller Type	
	1st Coat	2nd Coat
High Texture	Med. Texture	Med. Texture
Medium Texture	Nap	Med. Texture
Low Texture	Med. Texture	Nap
Ripple Texture	Nap	Nap

finish be prepared for approval and that finish shall act as the standard.

The length of the roller nap will vary the profile of the texture although the nap length must suit the substrate. A 10-12mm nap produces a low surface profile while a 15-18mm nap produces a higher surface profile.

### COVERAGE

#### EXTERNAL WALL MEMBRANE APPLICATION

1 x 15 litre unit will cover approximately 24 square metres in two coats at a total dry film thickness of 0.3mm.

#### ROOF MEMBRANE APPLICATION

1 x 15 litre unit will cover approximately 7 square metres in two coats at a total dry film thickness of 1.0mm.

Coverage will vary depending on the condition of the surface and film thickness.

### CLEANING & THINNING

Thinning is not necessary or recommended. Clean up with water before material has set and remove cured material with mineral turps.

## PROPERTY DATA

### Characteristics of liquid

Form & colour	Viscous Liquid in standard colours. Special colours on request at a premium.
Specific gravity	Approx. 1.3 g/cm <sup>3</sup>

### Characteristics of cured membrane

Water Vapour Transmission (ASTM E96)	
at 1.0mm	21.9 g/m <sup>2</sup> /24hrs
Tensile strength AS1145	
- after 28 days dry	2.1 MPa
- after 14 days	
UV exposure	3.0 MPa
- after 2,500 hrs	
QUV	5.9 MPa
Elongation at break AS1145	
- after 28 days dry	460%
- after 14 days	
UV exposure	315%
- after 2,500 hrs	
QUV	180%

### Application Details

#### Application method

- Textured roller, medium nap roller or brush for external wall membrane.
- Long nap roller or brush for roof membrane application.

Overcoat time	4 hrs @ 23°C, 50% RH
Dry through (2nd coat)	24hrs @ 23°C, 50% RH
Application temperature	10°C - 35°C (surface temp)
Service temperature	0-60°C

NOTE: Most of the tests have been carried under standard conditions (23±2 °C, 50±5% RH)

### SAFETY DATA

UN Number N/A. Non flammable and non explosive. Non toxic and non irritating. May cause skin irritation with some people after prolonged contact. It is recommended that protective gloves be used during application.

### FIRST AID

If poisoning occurs, contact a Doctor or the Poisons Information Centre. If swallowed, do NOT induce vomiting. Give a glass of water. If skin contact occurs, remove contaminated clothing and wash skin thoroughly. If in eyes, hold eyes open, flood with water for at least 15 minutes and see a Doctor.

ADDITIONAL INFORMATION IS LISTED IN THE MATERIAL SAFETY DATA SHEET





---

# ARDEX WPM 330

## Sheltercoat Facade Membrane

---

External Anti-Carbonation Facade Membrane

# ARDEX WPM 330

## Sheltercoat Facade Membrane

### External Anti-Carbonation Facade Membrane

#### PRODUCT DESCRIPTION

Ardex WPM 330 (Sheltercoat Facade) is an extremely weather resistant water based acrylic waterproofing membrane. Specially designed as an exposed facade membrane, Ardex Sheltercoat Façade prevents moisture, salt and carbon dioxide entering and damaging the building structure.

Ardex WPM 330 (Sheltercoat Facade) is also highly resistant to dirt retention, as well as containing fungi and algae growth inhibitors. The product's flexibility and high build qualities allow it to be applied over hairline cracks.

Ardex WPM 330 (Sheltercoat Facade) is water based, low in odour and is available in a range of decorative colours.

#### FEATURES/BENEFITS

- Highly flexible & durable
- Self cleaning, low dirt retention
- Resists fungi & algae growth
- Large range of durable colours
- Vapour permeable (allows facade substrate to breath)
- Prevents salt and carbon dioxide attack

#### ACCEPTABLE SUBSTRATES

After appropriate surface preparation:-

- Rendered walls
- Brick/masonry walls
- Fibre cement sheets
- Tilt up and pre-cast concrete
- Light weight aerated concrete blocks (eg CSR Hebel)

#### TYPICAL APPLICATIONS

- Building facades & external walls
- Roof parapets
- Silos, lighthouses & other external structures

Particularly important in coastal areas, high traffic density areas for application over concrete and brick surfaces.

#### LIMITATIONS

Product should not be used in trafficable areas. Other Ardex products are more suitable for this application. Do not apply Ardex WPM 330 (Sheltercoat Facade) if the surface temperature is below 10°C or above 35°C. Do not apply if rain is imminent.

#### BASIC APPLICATION INSTRUCTIONS

##### Surface preparation

The surface to be coated should be clean, sound, and free from oil, grease, form release agents or bondbreakers and other contaminants. All areas of loose or flaking paint must be removed to a firmly bonded substrate. Concrete surface pores must be open to enable good adhesion.

##### Cracks and voids

Ardex WPM 330 (Sheltercoat Facade) can be applied directly over hairline cracks. All other cracks should be treated with a neutral cure silicone. Other deep surface imperfections should be repaired with a repair mortar incorporating Ardex WPM 405 (Sheltercrete Additive) and allowed to cure for 7 days before applying the membrane. Refer to Ardex from advice regarding areas of concrete spalling. Irregular surfaces resulting from peeled paint should be smoothed using Adex Feather Finish.

##### Priming

All prepared surfaces should be primed with one coat of Ardex WPM 270 (Sheltercoat Solvent Based Primer) at a rate of 6m<sup>2</sup> per litre. AAC (Hebel) or other highly porous surfaces may require two coats. Allow primer to be dry before applying the membrane (approx. 30 minutes).

##### Application of Ardex WPM 330 (Sheltercoat Facade)

Apply with nap roller, textured roller or paint brush. Ensure that the coating is applied evenly at the recommended coverage rates.

Apply the first coat of Facade at a rate of 1 litre per 2.8m<sup>2</sup> to achieve a wet film thickness of 0.35mm, and allow it to dry.

Apply the second coat at approximately the same rate to achieve a final dry film thickness of around 0.35mm.

##### Surface Finish

The surface finish achieved can be varied by selection of method of application. Prior to the commencement

Surface Finish Profile	Roller Type	
	1st Coat	2nd Coat
High Texture	Med. Texture	Med. Texture
Medium Texture	Nap	Med. Texture
Low Texture	Med. Texture	Nap
Ripple Texture	Nap	Nap

of any project it is recommended that a sample of the finish be prepared for approval and that finish shall act as the standard.

The length of the roller nap will vary the profile of the texture although the nap length must suit the substrate.

A 10-12mm nap produces a low surface profile while a 15-18mm nap produces a higher surface profile.

## COVERAGE

Coverage: 1 x 15 litre unit of Ardex WPM 330 (Sheltercoat Facade) will cover approximately 20m<sup>2</sup> (at a dry film thickness, after two coats, of 0.35mm)

## SAFETY DATA

Product is non hazardous and non toxic. Eye contact: flush eye with clean water for 15 minutes.

If irritation continues seek medical advice. Inhalation: do not inhale intentionally. No danger from continued normal use. Skin contact: non hazardous. Wash skin with water before dry. Ingestion: do not induce vomiting. Seek medical attention immediately. Please contact Ardex for a Material Safety Data Sheet.

## STORAGE

The shelf life of Ardex WPM 330 (Sheltercoat Facade) is 12 months in the original unopened packaging when stored at 23°C. Do not store in direct sunlight. Replace lid tightly after use. Unused product should be used within 6 months of the container being opened.

## CLEAN UP & DISPOSAL

Clean all equipment with water prior to the product drying. Dispose containers in compliance with all relevant local authorities, state and federal laws and regulations.

## TECHNICAL PERFORMANCE DATA

Colour	Available in selected colour range
Specific Gravity	1.26g/cm <sup>3</sup>
Viscosity	60,000 cps
Volume Solids	49%
Application Temperature	10°C - 35°C
Drying time: (25°C/50% RH)	
Surface Dry	2 hours
Recoat	4 hours
Hard Dry	7 days
Lower temperature and higher humidity will prolong drying	
Carbon Dioxide diffusion resistance	
Kopfler criterion	(min reqd. R>50m) 124m
Water vapour transmission	
(ASTM E96-94)	39.8 g/m <sup>2</sup> /24 hrs
Kopfler criterion	
(max reqd Sd< 4m)	1.1m
Chloride ion diffusion resistance	
(as per TEL procedures)	7.7 x 10 <sup>-14</sup> m <sup>3</sup> /sec





---

# ARDEX WPM 345

## Sheltercoat Roof & Deck - 1 Part

---

Roof & Deck Waterproofing Membrane

---

# ARDEX WPM 345

## Sheltercoat Roof & Deck - 1 Part

### Roof & Deck Waterproofing Membrane

#### PRODUCT DESCRIPTION

Ardex WPM 345 (Sheltercoat Roof & Deck 1 Part) is a tough, UV stable, mildew resistant and flexible premixed liquid applied waterproofing membrane. It has been specifically formulated for exposed situations, and is available in a range of colours. In areas exposed to periodic foot traffic a layer of polyester mat should be incorporated into the system between coats.

#### FEATURES/BENEFITS

- Flexible - Accommodates normal building movement
- UV & fungus resistant – Provides long term protection from elements
- Excellent workability – Easy, quick to apply
- Decorative – Choice of colours
- Water based – Safe to use, low odour and easy cleaning

#### ACCEPTABLE SUBSTRATES

- Concrete, renders and screeds
- Masonry, concrete and AAC blocks
- Fibre cement sheets (external grade only)
- Preprimed metal

For use over existing paints, membranes, covering materials, and any other substrates contact Ardex Building Products for advice.

#### TYPICAL APPLICATIONS

External decks & floors, rooftops (new & existing), podiums, parapets. Ardex WPM 345 (Sheltercoat Roof & Deck 1 Part) is also ideal for areas that will be subjected to maintenance foot traffic.

#### LIMITATIONS

Do not use the product in the following situations:

- Areas subject to vehicular traffic
- When rain appears imminent
- Where solvent or petroleum based products could be spilled
- Where the surface temperature is below 5° or greater than 35°C

Do not attempt to thin down the mix with water, cement etc. Decks or balconies must have adequate falls. For substrates or situations other than those listed contact Ardex.

#### BASIC APPLICATION INSTRUCTIONS

Surface preparation

- Ensure all surfaces are structurally sound and totally dry. All sheet substrates must be securely fixed in accordance with the manufacturer's instructions.
- All areas to be waterproofed must have sufficient provision for drainage and falls of at least 1:80 or 25mm in 2m.
- The surface to be coated should be free from dust, oil, paint, curing compounds and any other contaminating materials.
- Damaged concrete should be repaired (levelled) and surface defects including all cracks and sharp protrusions should be treated prior to the application of the membrane.
- Remove laitance on concrete or screeds by mechanical means.
- Dense concrete (refer Priming) should be roughened by mechanical means.

#### Priming

To achieve proper adhesion it is critical to select the appropriate primer. Dense or steel trowelled concrete, or concrete that has been treated with an additive will normally require the use of Ardex WPM 270 (Sheltercoat Solvent Based Primer) to achieve proper adhesion.

Check the density of the substrate by pouring a small amount of water onto the substrate. If the substrate absorbs the water then Ardex WPM 265 (Sheltercoat Water Based Primer) can be used. If however, the water beads on the surface of the substrate the solvent based primer is recommended. Dense concrete must be mechanically roughened before priming.

Apply one coat of Ardex WPM 265 (Sheltercoat Water Based Primer) or Ardex WPM 270 (Sheltercoat Solvent Based Primer) by brush or roller to all areas to be waterproofed. Two coats are required when priming AAC or other highly porous substrates. Allow the primer to be completely dry prior to the application of the Ardex WPM 345 (Sheltercoat Roof & Deck 1 Part). This will take around 20-30 minutes depending upon weather conditions and porosity of the substrate.

Prime metal surfaces with a suitable metal primer. Plastic (eg. PVC) pipes should be primed with a solvent based PVC primer.

#### Application

Ardex recommends using a short pile roller (5mm) for applying Ardex WPM 345 (Sheltercoat Roof & Deck 1 Part) to achieve the best results. Ensure the roller is fully saturated and do not overwork the roller when applying.

### **Crack preparation**

Cracks less than 2mm: clean and remove any loose particles in the crack. Prime the area carefully before patching the crack with neutral cure silicone sealant. Extend the silicone 5mm either side of the crack along its entire length. Apply two coats of Ardex WPM 345 (Sheltercoat Roof & Deck 1 Part) over the crack to achieve a minimum dry film thickness of 1.2mm.

Cracks 2-6mm: prepare the crack and apply the silicone as described above. Apply a 300mm wide band of mixed Ardex WPM 345 (Sheltercoat Roof & Deck 1 Part) along the entire length of the crack.

Place a 200mm wide band of polyester reinforcement mat into the wet membrane. Remove any creases or air pockets in the mat. Immediately apply a second coat to completely fill the mat.

Cracks greater than 6mm: contact your local Ardex representative.

### **Movement/construction joints**

Clean and prime the joint and apply one coat of the membrane to the edge of the joint. Whilst the membrane is wet insert the Joint Bridging Band along the length of the joint. Immediately apply a second coat over the entire bandage.

### **Corners & coving areas**

After priming apply a generous bead (10mm) of neutral cured silicone sealant in coving areas and corners. Smooth over the silicone so that it extends 5mm up the wall and 5mm over the floor. Apply a first coat of Ardex WPM 345 (Sheltercoat Roof & Deck 1 Part) to the area and whilst the membrane is still wet insert a layer of reinforcement material. Immediately apply the second coat ensuring that any wrinkles in the material are removed.

### **Vertical surfaces**

After priming apply two coats of Ardex WPM 345 (Sheltercoat Roof & Deck 1 Part) in two opposite directions on vertical surfaces. Take the membrane up underneath any existing cover flashing or install appropriate flashing. Allow the first coat to dry before applying the second coat. The top of the parapet should be waterproofed with Sheltercoat or covered with suitable metal capping, render or protective coating.

### **Horizontal surfaces**

Apply a first coat of Ardex WPM 345 (Sheltercoat Roof & Deck 1 Part) over the primed surface. Place the polyester or fibreglass reinforcing mat over the first coat whilst the membrane is still wet. Ensure that the mat is fully bedded into the membrane, with no air pockets and creases. Apply a second coat of Ardex WPM 345 (Sheltercoat Roof & Deck 1 Part) over the mat as soon as it is fully bedded into the base coat.

Allow the membrane to fully cure before being subjected to full service foot traffic. This will take approximately 7 days at 23°C and 50% RH.

### **Roof & balcony penetrations**

Place a suitable flanged metal upstand around the penetration. Prime the metal with an appropriate metal primer and allow to dry. Apply a 10mm bead of silicone around the perimeter of the penetration. Apply the first coat of Ardex WPM 345 (Sheltercoat Roof & Deck 1 Part) on the substrate and the flanged metal. Allow first coat to dry before applying a second coat

ensuring a finished dry film thickness of no less than 1.2mm is achieved. Place a suitable flashing collar around the penetration sealing it with an elastomeric sealant.

### **COVERAGE**

Approximately 8m<sup>2</sup> per 20 litre unit at a dry film thickness of 1.2mm.

Coverage will vary depending on the condition of the surface and film thickness.

### **DRYING TIME**

Allow 4 hours between coats (at 23°C and 50% RH) if a reinforcing material is not used. When using a reinforcing material it should be embedded in the wet membrane and immediately overcoated. The membrane is fully dry within 24 hours (at 23°C and 50% RH), after which it can be subjected to light foot traffic. Avoid full service foot traffic until the membrane is fully cured (7 days at 23°C, 50% RH). Pot life is approximately 3 hrs at 23°C and 50% RH.

Drying time will vary depending on humidity, temperature and surface porosity.

Do not apply on substrates where the surface temperature is below 5°C or above 35°C.

### **SAFETY DATA**

Ardex WPM 345 (Sheltercoat Roof & Deck 1 Part) is non-toxic. However, the contents should not be swallowed or inhaled. In case of eye contamination, rinse thoroughly with clean water. If irritation continues seek medical advice.

### **PACKAGING/STORAGE**

One component: 20 litre PVC bucket.

### **CLEAN UP & DISPOSAL**

Wash hands, brushes, rollers, etc, with water while the membrane is still fresh.

Remove cured material with mineral turpentine. Remove

# ARDEX WPM 345

## Sheltercoat Roof & Deck - 1 Part Roof & Deck Waterproofing Membrane

---

any food or drink stains immediately with warm water and a mild household detergent.

Dispose of containers in compliance with all relevant local, state, and federal regulations.

### TECHNICAL PERFORMANCE DATA

#### Characteristics of liquid

Form & colour	Grey or white medium viscosity liquid
Specific gravity	Approx. 1.206g/cm <sup>3</sup>
Characteristics of cured membrane	
Water absorption	AS A121 App K 6.5%
Tensile strength	
28 days dry	AS1145 4.0 MPa
after UV exposure	5.5 MPa
Elongation at break	
28 days dry	AS1145 300%
after UV exposure	325%
Application details	
Application method	short nap (5mm pile) roller, brush, or airless spray
Overcoat time (without mat)	
	4 hrs @ 23°C 50% RH
Dry through (2nd coat)	24hrs @ 23°C 50% RH
Application temperature	5°C - 30°C (surface temp)
Service temperature	0-60°C
Coverage	Approx 8m <sup>2</sup> per 20 litre unit at 1.2mm DFT

NOTE: Most of the tests have been carried out in a Ardex laboratory under standard conditions (23±2°C, 50±5% R.H)



---

# ARDEX WPM 350

## Sheltercoat Roof & Deck - 2 Part

---

Roof & Deck Waterproofing Membrane

# ARDEX WPM 350

## Sheltercoat Roof & Deck - 2 Part Roof & Deck Waterproofing Membrane

### PRODUCT DESCRIPTION

Ardex WPM 350 (Sheltercoat Roof & Deck 2 Part) is a tough, UV stable, mildew resistant and flexible liquid applied waterproofing membrane. It has been specifically formulated for exposed situations, and is available in a range of colours. The reinforced liquid component eliminates the need for reinforcement mat in most situations. In heavy foot traffic areas a layer of polyester mat and a two final coats of Ardex WPM 355 (Sheltercoat Protective Finish) should be incorporated into the system.

### SYSTEM

#### Light foot traffic areas

(ie. service traffic)

Ardex WPM 265 (Sheltercoat Water Based Primer) or  
Ardex WPM 270 (Sheltercoat Solvent Based Primer)

Ardex WPM 350 (Sheltercoat Roof & Deck 2 Part)  
(first coat)

Ardex WPM 350 (Sheltercoat Roof & Deck 2 Part)  
(second coat)

Optional: Ardex WPM 355  
(Sheltercoat Protective Finish)  
(2 coats)

#### Med.-high foot traffic areas

(ie. medium foot traffic)

Ardex WPM 265 (Sheltercoat Water Based Primer) or  
Ardex WPM 270 (Sheltercoat Solvent Based Primer)

Ardex WPM 350 (Sheltercoat Roof & Deck 2 Part) Ardex  
Deckweb reinforcement  
(first coat)

Ardex WPM 350 (Sheltercoat Roof & Deck 2 Part)  
(second coat)

Ardex WPM 350 (Sheltercoat Roof & Deck 2 Part)  
(third coat)

Ardex WPM 355 (Sheltercoat Protective Finish) (2 coats)

### FEATURES/BENEFITS

- Provides tough, hardwearing surface
- Flexible
- UV & fungus resistant
- Easy, quick to apply
- Choice of colours
- Optional Protective Coat
- Safe to use, low odour & easy cleaning

Ardex WPM 355 (Sheltercoat Protective Finish) is a tough protective coating available in a range of decorative colours. When applied over Ardex WPM 350 (Sheltercoat Roof & Deck 2 Part) , the Protective Finish greatly improves wearability, ease of cleaning and surface appearance.

### ACCEPTABLE SUBSTRATES

- Concrete, renders and screeds
- Masonry, concrete & AAC blocks
- Fibre cement sheets (external grade only)
- Preprimed metal

For use over existing paints, membranes, covering materials, and any other substrates contact Ardex for advice.

### TYPICAL APPLICATIONS

External decks & floors, rooftops (new & existing), podiums, parapets. External timber decks should be waterproofed with Ardex Butynol membrane) Ardex WPM 350 (Sheltercoat Roof & Deck 2 Part) is also ideal for areas that will be subjected to light foot traffic before being tiled.

### LIMITATIONS

Do not use the product in the following situations:

- Areas subject to vehicular traffic
- When rain appears imminent
- Where solvent or petroleum based products could be spilled
- Where the surface temperature is below 5°C or greater than 35°C

Do not attempt to thin down the mix with water or mix with other products such as cement etc. Decks or balconies must have adequate falls. Ensure sharp edges of table or chair legs are protected. For substrates or situations other than those listed contact Ardex.

### BASIC APPLICATION INSTRUCTIONS

#### Surface preparation

- Ensure all surfaces are structurally sound and totally dry. All sheet substrates must be securely fixed in accordance with the manufacturers instructions.
- All areas to be waterproofed must have sufficient provision for drainage and falls of at least 1:80 or 25mm in 2m.
- The surface to be coated should be free from dust, oil, paint, curing compounds and any other contaminating materials.
- Damaged concrete should be repaired (leveled) and surface defects including all cracks and sharp protrusions should be treated prior to the application of the membrane.
- Remove laitance on concrete or screeds by mechanical means.
- Dense concrete (refer Priming) should be roughened by mechanical means.

## Mixing

Mixing ratio is 1:1 by weight (ie. 10kg liquid to 10kg powder). Mix with a slow speed mechanical stirrer until there are no lumps in the mixture. Allow to stand for 5 minutes, then re-stir before use.

## Priming

To achieve proper adhesion it is critical to select the appropriate primer. Dense or steel trowelled concrete, or concrete that has been treated with an additive will normally require the use of Ardex WPM 270 (Sheltercoat Solvent Based Primer) to achieve proper adhesion. Ardex WPM 270 (Sheltercoat Solvent Based Primer) is also recommended for external applications.

Check the density of the substrate by pouring a small amount of water onto the substrate. If the substrate absorbs the water then Ardex WPM 265 (Sheltercoat Water Based Primer) can be used. If however, the water beads on the surface of the substrate or is absorbed slowly the solvent based primer is recommended. Dense concrete must be mechanically roughened to open the concrete pores before priming.

Apply one coat of Ardex WPM 265 (Sheltercoat Water Based Primer) or Ardex WPM 270 (Sheltercoat Solvent Based Primer) by brush or roller to all areas to be waterproofed. Two coats are required when priming AAC or other highly porous substrates. Allow the primer to be completely dry prior to the application of Ardex WPM 350 (Sheltercoat Roof & Deck 2 Part). This will take around 20-30 minutes depending upon weather conditions and porosity of the substrate.

In hot climates where there is a risk of the existence of substrate moisture surfaces may be primed with Ardex WPM 300 (HydrEpoxy 300) at a coverage rate of 3.0 square metres per litre to minimize the risks of the Ardex WPM 350 (Sheltercoat Roof & Deck 2 Part) forming blisters during drying and curing.

Prime metal surfaces with a suitable metal primer. Plastic (eg. PVC) pipes should be primed with a solvent based PVC primer.

## Application

Ardex recommends using a medium pile roller (10-15 mm) for applying Ardex WPM 350 (Sheltercoat Roof & Deck 2 Part) to achieve the best results. Ensure the roller is fully saturated and do not press hard on the roller when applying.

## Crack preparation

### Cracks <2mm (refer Fig. 1)

Clean and remove any loose particles in the crack. Prime the area carefully before patching the crack with neutral cure silicone sealant. Extend the silicone 5mm either side of the crack along its entire length. Apply two coats of Ardex WPM 350 (Sheltercoat Roof & Deck 2 Part) over the crack to achieve a minimum dry film thickness of 1.2mm.

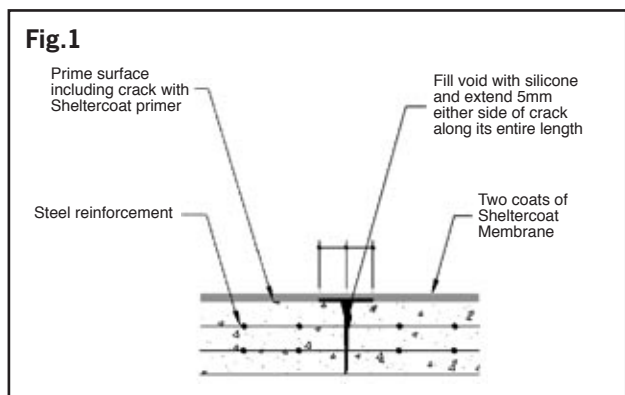

### Cracks 2-6mm

Prepare the crack and apply the silicone as described above. Apply a 300mm wide band of mixed Ardex WPM 350 (Sheltercoat Roof & Deck 2 Part) along the entire length of the crack. Place a 200mm wide band of polyester reinforcement mat into the wet membrane. Remove any creases or air pockets in the mat. Immediately apply a second coat to completely fill the mat.

### Cracks >6mm

contact your local Ardex representative.

## Movement/construction joints

### Movement joints (<6mm)

Clean and prime the joint before filling it with a bead of neutral cure silicone and extending it 5mm each side of joint. Apply a 300mm wide band of mixed Ardex WPM 350 (Sheltercoat Roof & Deck 2 Part) along the entire length of the joint and use reinforcing mat as a slip membrane over the joint. Sheet joints should be treated similarly (refer Fig.2).

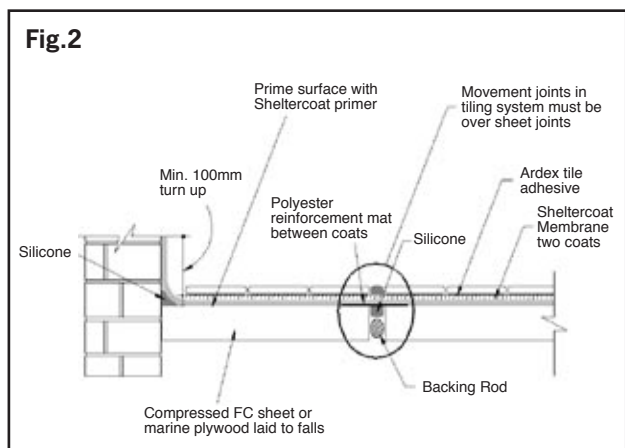

# ARDEX WPM 350

## Sheltercoat Roof & Deck - 2 Part

### Roof & Deck Waterproofing Membrane

#### Construction joints (>6mm)

Clean and prime the joint and apply one coat of the membrane to the edge of the joint. Whilst the membrane is wet insert the Ardex Joint Bridging Band along the length of the joint. Immediately apply a second coat over the entire bandage. Note: if tiling, movement joints should be taken to the surface of the tiles. Fill the joints between the tiles on top of the movement joints with an appropriate joint sealant. (refer Fig. 3)

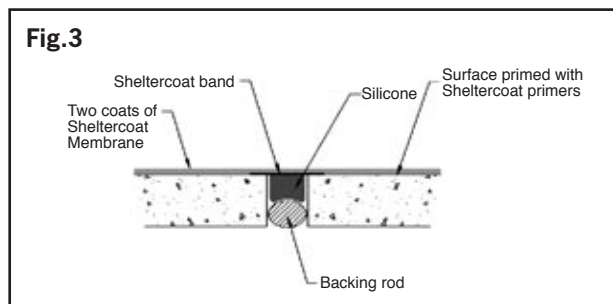

#### Corners & coving areas

After priming apply a generous bead (10mm) of neutral cured silicone sealant in coving areas and corners. Smooth over the silicone so that it extends 5mm up the wall and 5mm over the floor. Apply a first coat of Ardex WPM 350 (Sheltercoat Roof & Deck 2 Part) to the area and allow the membrane to dry. Apply a second coat ensuring that excess product is removed from the junction (the final dry film thickness should be around 1.2-1.5mm). For heavy foot traffic areas a reinforcing mat is required between coats.

#### Vertical surfaces

After priming apply two coats of Ardex WPM 350 (Sheltercoat Roof & Deck 2 Part) in opposite directions on vertical surfaces. Take the membrane up underneath any existing cover flashing or install appropriate flashing. Allow the first coat to dry before applying the second coat. The top of the parapet should be waterproofed with Ardex WPM 310 or Ardex WPM 330 or covered with suitable metal capping, render or protective coating (refer Fig.4).

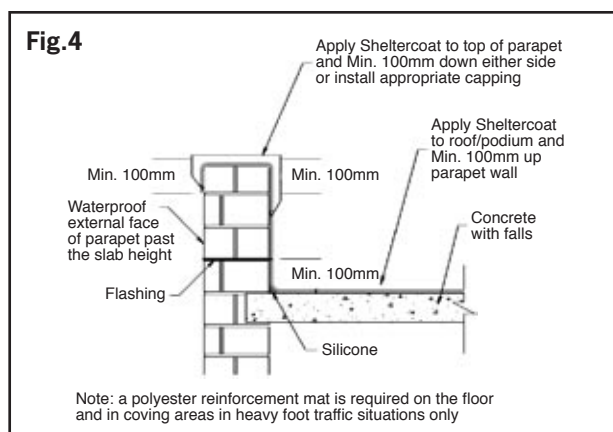

#### Horizontal surfaces

##### Light (occasional) foot traffic areas

Two coats of Ardex WPM 350 (Sheltercoat Roof & Deck 2 Part) are required to achieve the correct dry film thickness of 1.2-1.5mm. Apply the first coat over the primed surface and allow it to dry (4 hours at 23°C, 50% RH) before applying a second coat in an opposite direction.

##### Optional

The application of Ardex WPM 355 (Sheltercoat Protective Finish) is recommended as it will greatly improve the durability and cleanability of the surface. Apply one coat of Ardex WPM 355 (Sheltercoat Protective Finish) to the entire area once the top coat of the membrane is dry (approximately 24 hours).

##### Medium/heavy (regular) foot traffic areas

In heavy foot traffic areas, three coats of Ardex WPM 350 (Sheltercoat Roof & Deck 2 Part), one layer of polyester reinforcement mat and two coats of Ardex WPM 355 (Sheltercoat Protective Finish) are required to achieve the correct dry film thickness of 2-2.5mm.

Apply a first coat of Ardex WPM 350 (Sheltercoat Roof & Deck 2 Part) over the primed surface. Place the polyester reinforcing mat over the first coat whilst the membrane is still wet. Ensure that the mat is fully bedded into the membrane, with no air pockets and creases. Apply a second coat of Ardex WPM 350 (Sheltercoat Roof & Deck 2 Part) over the mat as soon as it is fully bedded into the base coat.

Allow the second coat to dry (approx. 24 hours at 23°C, 50% RH) before applying a liberal final coat of Ardex WPM 350 (Sheltercoat Roof & Deck 2 Part). Alternatively, bed another layer of mat into the wet second coat of Ardex WPM 350 (Sheltercoat Roof & Deck 2 Part) and apply a third coat of Ardex WPM 350 (Sheltercoat Roof & Deck 2 Part). Finally apply two coats of Ardex WPM 355 (Sheltercoat Protective Finish) to the surface once the third coat of the membrane is dry (approx 24 hrs at 23°C, 50% RH). Allow the membrane to fully cure before being subjected to full service foot traffic. This will take approximately 7 days at 23°C, 50% RH.

#### Roof & balcony penetrations

Place a suitable flanged metal upstand around the penetration. Prime the metal with an appropriate metal primer and allow to dry. Apply a 10mm bead of silicone around the perimeter of the penetration. Apply the first coat of Ardex WPM 350 (Sheltercoat Roof & Deck 2 Part) on the substrate and the flanged metal. Allow first coat to dry before applying a second coat ensuring a finished dry film thickness of no less than 1.2mm is achieved. Place a suitable flashing collar around the penetration sealing it with a suitable sealant.

For heavy foot traffic areas a reinforcing mat is required between coats.

## COVERAGE

2 coat system (light traffic): 20m<sup>2</sup> per unit of 20kg liquid/2x10kg powder at a dry film thickness of 1.5mm.

3 coat/mat system (heavy traffic): 13m<sup>2</sup> per unit of 20kg liquid/2x10kg powder at a dry film thickness of 2.5mm

Coverage will vary depending on the condition of the surface and film thickness.

## DRYING TIME

Allow 4 hours between coats (at 23°C, 50% RH) if a reinforcing material is not used. When using a reinforcing material it should be embedded in the wet membrane and immediately overcoated. The membrane is fully dry within 24 hours (at 23°C, 50% RH), after which it can be subjected to light foot traffic. Avoid full service foot traffic until the membrane is fully cured (7 days at 23°C, 50% RH). Pot life is approximately 3 hrs at 23°C, 50% RH.

Drying time will vary depending on humidity, temperature and surface porosity.

Do not apply on substrates where the surface temperature is below 5°C or above 35°C.

## SAFETY DATA

Ardex WPM 350 (Sheltercoat Roof & Deck 2 Part) is non-toxic. However, the contents should not be swallowed or inhaled. In case of eye contamination, rinse thoroughly with clean water. If irritation continues seek medical advice.

## PACKAGING/STORAGE

Product sold as two components: Part A 20kg bucket liquid, Part B 20kg bucket containing 2 x 10kg bags of powder.

## CLEAN UP & DISPOSAL

Wash hands, brushes, rollers, etc, with water while the membrane is still fresh. remove cured material with mineral turpentine. Remove any food or drink stains immediately with warm water and a mild household detergent.

Dispose of containers in compliance with all relevant local, state, and federal regulations.

## TECHNICAL PERFORMANCE DATA

### Characteristics of liquid

Form & Colour	Various coloured liquids
---------------	--------------------------

Specific Gravity	Approx. 1.06kg/litre
------------------	----------------------

### Characteristics of powder

Form & Colour	Off white powder
---------------	------------------

Bulk Density	Approx. 1.4kg/litre
--------------	---------------------

### Characteristics of mix

Product Identity	2 part, cementitious acrylic modified
------------------	---------------------------------------

Mixing Ratio	1:1 by Weight (10kg of Powder: 10kg of Liquid)
--------------	--

Specific Gravity	Approx. 1.3
------------------	-------------

### Characteristics of cured membrane

Water absorption	AS A121 App K 5%
------------------	------------------

### Tensile Strength - AS1145

28 days dry	1.97 MPa
-------------	----------

after UV exposure	2.32 MPa
-------------------	----------

### Elongation at Break - AS1145

28 days dry	208%
-------------	------

after UV exposure	155%
-------------------	------

### Movement joint test

- CSIRO	Pass
---------	------

### Application Details

Application method	Roller (medium 8-12mm pile nap), brush
--------------------	--

Overcoat time	4 hrs @ 23°C, 50% RH
---------------	----------------------

Pot life	3 hrs @ 23°C, 50% RH
----------	----------------------

Dry through (2nd coat)	Overnight @ 23°C, 50% RH
------------------------	--------------------------

Application temperature	5°C-30°C (surface temp)
-------------------------	-------------------------

Service temperature	0-80°C
---------------------	--------

Coverage	Approx 20m <sup>2</sup> per 20kg liquid/ 2x10kg powder at 1.5mm DFT
----------	---

NOTE: Most of the tests have been carried out in a Ardex laboratory under standard conditions (23±2°C, 50±5% RH)





---

# ARDEX WPM 157

## Polyurethane Membrane

---

1 Part Moisture Cured Polyurethane Membrane

# ARDEX WPM 157

## Polyurethane Membrane

### 1 Part Moisture Cured Polyurethane Membrane

#### DESCRIPTION

Ardex WPM 157 (Polyurethane Membrane) is one component moisture cured polyurethane system for waterproofing and flooring.

#### FEATURES/BENEFITS

- Excellent flexibility
- One component
- Good adhesion to a wide range of substrate
- Excellent chemical resistance
- Decrease of construction cost and time
- Can be applied as a single coat finish

#### TYPICAL APPLICATIONS

- Planter box internals
- Roof and Deck areas that are to be paved over sand bed, ballasted or otherwise covered without bonding.

#### APPLICATION

Application by squeegee, brush or roller (spray application only with adequate protective gear).

Ardex WPM 157 (Polyurethane Membrane) must be applied to dry surfaces with a moisture content of less than 7%. If doubt exists regarding the moisture content of the substrate, surface should be primed with Ardex WPM 300 (HydrEpoxy 300) and allowed to cure overnight before application of the Ardex WPM 157 (Polyurethane Membrane).

Ardex WPM 157 (Polyurethane Membrane) should be applied at the required coverage rate. In the event that this coverage rate is not achieved in one coat a second coat must be applied within a maximum of 24 hours to achieve an intercoat bond.

#### Priming

Prime wet or damp surfaces and concrete less than 28 days old with Ardex WPM 300 (HydrEpoxy 300) at a coverage rate of not more than 3.0 square metres per litre.

Prime dry porous surfaces with Ardex WPM 270 (Sheltercoat Solvent Based Primer) at a coverage rate of approximately 6 square metres per litre.

#### Application method

It is preferred that the application of the Ardex WPM 157 (Polyurethane Membrane) be carried out over a primed surface.

Apply the Ardex WPM 157 (Polyurethane Membrane) in one application to achieve an overall dry film thickness of 1.0mm for non-trafficable surfaces - 3.0mm for trafficable surfaces

Application using a squeegee, roller or brush (multiple coating in two direction application) is recommended. Subsequent coats must be applied within 24 hours of the preceding coat.

During application full suitable protective clothing should be employed. If using in areas of low ventilation full external breathing apparatus should be used.

#### LIMITATIONS

Bonding of ceramic tiles or other hard coverings is not recommended.

Topping screeds should be self supporting (ie reinforced), should be at least 40mm thick and applied over a suitable slip sheet.

Ardex WPM 157 (Polyurethane Membrane) must be applied to dry surfaces.

Ardex WPM 157 (Polyurethane Membrane) should not be applied without the necessary protective clothing - refer safety data.

This product is very sensitive to air, therefore containers cannot be resealed for future use once they have been opened.

#### THINNING AND CLEAN UP

Thinning of Ardex WPM 157 (Polyurethane Membrane) is not required since this will inhibit the ability to achieve the dry film thickness. If thinning is required the addition of up to 10% of xylene should be used.

Roller sleeves and brushes should be considered as consumables and disposed of following application. Other clean up may be done using xylene or other high aromatic hydrocarbon solvent.

#### SAFETY

Ardex WPM 157 (Polyurethane Membrane) contains isocyanates. Appropriate protective clothing must be worn during application.

The material safety data should be referred to before use. The Material Safety Data Sheet is available from Ardex upon request.

---

## TECHNICAL PERFORMANCE DATA

Appearance	Coloured viscous liquid
Viscosity	5,000±2,000 cps/25°C
Density	1.4±0.1 (g/cm <sup>3</sup> )
Solid Content (%)	92±2
Tack Free Time (hrs at 25°C, 60% RH)	max 3
Curing Time (hrs at 25°C, 60% RH)	
Coating Thickness 1.0mm	max 24
Coating Thickness 3.0mm	24 - 48
Properties of Film	
Hardness (Shore A)	70±10
Tensile Strength (kg/cm <sup>2</sup> )	over 35 (3.43MPa)
Elongation (%)	over 500
Tear Strength (kg/cm)	over 20 (1.96MPa)

## HANDLING & STORAGE

Ardex WPM 157 (Polyurethane Membrane) can be stored for 6 months at below 25°C. Avoid prolonged exposure to humidity or temperature above 50°C. Avoid contamination with water or alcohols.

## PACKING

20kgs (nominal 14.91 litres) in a metal container.





---

# ARDEX WPM 320

## Sheltercoat Retaining Wall - 1 Part

---

Bitumen Emulsion Waterproofing Membrane

# ARDEX WPM 320

## Sheltercoat Retaining Wall - 1 Part Bitumen Emulsion Waterproofing Membrane

### PRODUCT DESCRIPTION

Ardex WPM 320 (Sheltercoat Retaining Wall) is a one component liquid applied, latex modified, bituminous elastomeric waterproofing membrane. When cured it forms a permanently flexible waterproof lining to most building surfaces. It is tough, economical and easy to use. Specially formulated incorporating a root inhibitor, Ardex WPM 320 (Sheltercoat Retaining Wall) contains a premium root inhibitor that repels root growth without killing the root.

Designed primarily for areas covered or exposed to soil, it has excellent adhesion properties, can be applied to damp substrates, and dries relatively quickly. Ardex WPM 320 (Sheltercoat Retaining Wall) is waterbased, has almost no odour and is safe to use.

Where used externally, Ardex WPM 320 (Sheltercoat Retaining Wall) should be protected from Ultra Violet light.

### FEATURES/BENEFITS

- Water based: safe, low odour.
- Easily applied: single pack, high build, long pot life
- Tough/durable: provides long term protection
- Contains an effective root inhibitor that repels most root growth that may damage the membrane without killing the plant
- Excellent adhesion: can be applied to damp or dry
- Compatible with Ardex bitumen torch applied membranes

### ACCEPTABLE SUBSTRATES

- Concrete, screeds/renders - cured for a min 28 days and 14 days respectively. Alternatively apply a barrier coat of Ardex WPM 300 (HydrEpoxy 300) as a barrier coating to fresh or wet substrates).
- Masonry & concrete blocks - voids filled, sharp edges and protrusions should be removed to give flush finish.

### TYPICAL APPLICATIONS

- Compatible with all Ardex sheet and liquid membranes
- Planter boxes
- Retaining walls
- Lapping Ardex acrylic façade membrane to Ardex bitumen torch applied membranes

The product should not be used under tiles. Membranes containing bitumen can cause discolouration and disbonding of tiled surfaces over time.

### LIMITATIONS

Ardex WPM 320 (Sheltercoat Retaining Wall) will not resist root growth from large trees or other plants placed in close proximity.

Do not apply Ardex WPM 320 (Sheltercoat Retaining Wall) if the surface temperature is below 8°C or above 32°C. Do not apply if rain is imminent. Do not leave membrane exposed to direct UV rays for more than 3 weeks. Do not use solvent-based adhesive or sealers on top of membrane.

### BASIC APPLICATION INSTRUCTIONS

#### Surface preparation

The surface to be coated should be clean, sound and free from oils, greases and flaking paint. New concrete should be cured for 28 days (or a barrier coat of Ardex WPM 300 (HydrEpoxy 300) applied) prior to application of membrane and the surface pores must be open. All cracks or holes exceeding 2mm are to be repaired before application commences. Surface may be slightly damp but must be free from seeping moisture.

#### Priming

Ardex WPM 320 (Sheltercoat Retaining Wall) is self-priming on most surfaces. Wet or freshly placed concrete surfaces should be sealed with Ardex WPM 300 (HydrEpoxy 300) in one coat at a coverage rate of 3.0 square metres per litre. Porous substrates such as aerated concrete should be primed with Ardex WPM 320 (Sheltercoat Retaining Wall) mixed with 50% water.

#### Application

Apply 2 coats of Ardex WPM 320 (Sheltercoat Retaining Wall) at a total rate of 2.0 litres per m<sup>2</sup>, and ensure full coverage with brush or roller. A reinforcing fabric should be used between coats in all vertical and horizontal corners or other possible movement joints. Ardex WPM 320 (Sheltercoat Retaining Wall) may be fully reinforced if required such as over concrete block walls.

When dry, check for pinholes and rectify if necessary.

### COVERAGE

1 x 20 litre unit will cover approximately 12m<sup>2</sup> after two coats (recommended total dry film thickness minimum 1.0mm)

### DRYING TIME

Allow 1-2 hours between coats, unless a reinforcement material is used between coats. In this case, the second coat can be applied immediately after the mat has been installed in the wet first coat.

The membrane is fully dry in 24 hours.

---

## SAFETY DATA

Ardex WPM 320 (Sheltercoat Retaining Wall) - One Part is non-toxic, however the product should not be swallowed or inhaled. In case of eye contamination, rinse thoroughly with clean water. If irritation continues seek medical advice.

Contact Ardex for specific applications and material safety data sheets.

## STORAGE

Ardex WPM 320 (Sheltercoat Retaining Wall) is sold in 20 litre PVC Pails. Shelf life is 12 months when stored in the original unopened container, in a dry place at 25°C. Do not store in direct sunlight. Replace lid tightly after use.

## CLEAN UP & DISPOSAL

Clean all equipment in fresh water immediately after use. Remove cured material with mineral turpentine or white spirits. Dispose of containers in compliance with all relevant local authorities, state, and federal regulations.

## TECHNICAL PERFORMANCE DATA

Appearance & Odour	Thick black fluid, slight odour
Specific Gravity	Approx. 1.03g/cm <sup>3</sup>
Application temperature	10°C - 35°C
Drying Time: (@ 23°C, 50% RH)	
Recoat	2 - 4 hours
Hard Dry	24 - 48 hours
Full Cure	7 days
Tensile Strength: 6 days @ 23°C/50% RH	
plus 24 hrs at 70°C	1.8MPa
Elongation of break: 6 days @ 23°C, 50% RH	
plus 24 hrs at 70°C	220%





---

# ARDEX WPM 355

## Sheltercoat Protective Finish

---

High Wearing Acrylic Protective Finish

# ARDEX WPM 355

## Sheltercoat Protective Finish

### High Wearing Acrylic Protective Finish

#### PRODUCT DESCRIPTION

Ardex WPM 355 (Sheltercoat Protective Finish) is a single part acrylic based pigmented sealer. It has been specifically developed for use over Ardex WPM 350 (Sheltercoat Roof & Deck 2 Part) membranes in exposed medium-high (regular) foot traffic situations.

#### FEATURES/BENEFITS

- Hard wearing, flexible coating.
- Water based, environmentally friendly.
- Easy to apply, tack free.
- Smooth semi-gloss appearance.
- Excellent UV & fungi resistance.
- Improves cleanability of Ardex WPM 350 (Sheltercoat Roof & Deck 2 Part) system.

#### ACCEPTABLE SUBSTRATES

- Ardex WPM 350 (Sheltercoat Roof & Deck) acrylic membranes
- Ardex WPM 185 (Shelterbit Mineral) torch-on membrane
- Ardex Butynol rubber membranes

#### LIMITATIONS

Ardex WPM 355 (Sheltercoat Protective Finish) should be used in conjunction with a high build, liquid membrane or sheet membrane. It is not intended to be used as a waterproofing membrane in its own right.

#### BASIC APPLICATION INSTRUCTIONS

##### Surface preparation:

Make sure the membrane to be coated is sound, clean and free from contaminating material. Liquid membranes must also be thoroughly dry. If rain is imminent do not apply the coating. Stir the contents before use to ensure the colour is consistent.

##### Application over freshly applied liquid membranes:

Wait until the last coat of the Ardex WPM 350 (Sheltercoat Roof & Deck 2 Part) membrane is completely dry (24 hrs @23°C, 50% RH). Apply one heavy coat (wet film thickness 0.35mm) of Ardex WPM 355 (Sheltercoat Protective Finish) with a medium-long pile (12-20mm) roller. Saturate the roller to achieve a substantial and consistent film. Do not overwork the coating as this can cause excess air to build-up in the film. In areas subject to the heaviest traffic/abrasion, eg. balcony step-downs, two coats of Ardex WPM 355 (Sheltercoat Protective Finish) are recommended.

##### Application to old liquid membranes & recoating:

If Ardex WPM 355 (Sheltercoat Protective Finish) is to be applied on a liquid membrane which has already been exposed to foot traffic the entire surface should be cleaned with warm water. A mild household detergent can be used if necessary. Wait for the substrate to be completely dry before priming the membrane with one light coat of Ardex WPM 270 (Sheltercoat Solvent Based Primer). Once the primer is completely dry apply one heavy coat of Ardex WPM 355 (Sheltercoat Protective Finish) to the entire surface.

It may be necessary to re-coat the Ardex WPM 355 (Sheltercoat Protective Finish) over time depending upon the frequency and nature of foot traffic. Before recoating Ardex WPM 355 (Sheltercoat Protective Finish) thoroughly clean the area to be recoated with water and allow to dry. Apply a heavy coat of Ardex WPM 355 (Sheltercoat Protective Finish) and allow it to cure to its full strength (7 days) before subjecting it to foot traffic.

##### Application over Ardex Shelterbit Mineral

Note that Ardex WPM 355 (Sheltercoat Protective Finish) is not designed for application over other than Ardex Shelterbit Mineral.

Lightly broom clean the surface to remove excess loose mineral before applying 2 liberal coats of Ardex WPM 355 (Sheltercoat Protective Finish).

##### Application over Butynol:

Clean old Butynol surface thoroughly with sugar soap (trafficable areas need a further wipe using WA98 solvent). Apply one coat of Ardex WPM 299 (Seam Primer) to the cleaned Butynol surface at an approximate rate of 6m<sup>2</sup>/litre. Apply with brush or roller. Wait for the primer to dry before applying two coats of Ardex WPM 355 (Sheltercoat Protective Finish) to the entire area.

##### Application Hints:

For best results choose a light coloured Ardex WPM 350 (Sheltercoat Roof & Deck 2 Part) underneath Ardex WPM 355 (Sheltercoat Protective Finish). Apply Ardex WPM 355 (Sheltercoat Protective Finish) with a medium-long (12-15mm) nap roller.

#### COVERAGE

One (1) unit of 15L will cover approximately 45m<sup>2</sup> when applied at the correct film thickness.

#### DRYING TIME

Re-coat time: 2hours @ 23°C, 50% RH

Dry through time: overnight @ 23°C, 50% RH

Full cure time: 7 days @ 23°C, 50% RH

---

**SAFETY DATA**

Ardex WPM 355 (Sheltercoat Protective Finish) is non-toxic. However, the contents should not be swallowed or inhaled. In case of eye contamination, rinse thoroughly with clean water. If irritation continues seek medical advice.

**PACKAGING/STORAGE**

One component: 15 litre bucket liquid (18.6 kg).

**CLEAN UP & DISPOSAL**

Wash hands, brushes, rollers, etc, with water while the membrane is still fresh. Remove cured material with mineral turpentine. Remove any food or drink stains immediately with warm water and a mild household detergent. Dispose of containers in compliance with all relevant local authorities, state, and federal regulations.

**TECHNICAL PERFORMANCE DATA**

Form & Colour	Medium viscosity coloured liquid
Specific Gravity	Approx. 1.24g/cm <sup>3</sup>
Application Temperature	
Surface Temperature	10-30°C
Service Temperature	0-80°C
Tensile Strength	
(28 days dry): AS1145	3.6MPa
Elongation at Break	
(28 days dry): AS1145	280%
Adhesion to Membrane	
ASTM D4541	>0.7MPa





---

# ARDEX Tufftex

---

# ARDEX Tufftex

---

## DESCRIPTION

Ardex Tufftex is a tough wearing, acrylic, UV resistant coating. Ardex Tufftex can be applied over a variety of membrane systems to provide a non-slip finish or textured surface.

## TYPICAL APPLICATIONS

- Textured coating for building facades
- Non-slip surface for walkways
- Wearing protection over membrane systems

## APPLICATION REQUIREMENTS

### General

Do not apply Ardex Tufftex if the temperature is below 10°C or above 35°C. Do not apply Ardex Tufftex if rain is imminent.

### Substrate preparation

The surface to be coated should be dry, clean, sound and free from oil, grease and flaking paint. Sound paint may be over-coated. New concrete should be left a minimum of 28 days before application commences. All cracks or holes exceeding 2mm are to be repaired before application commences.

## APPLICATION SPECIFICATION

### Primer (to concrete surfaces)

Apply one coat of Ardex Bonding Primer (solvent based) to the prepared surface, at an approximate rate of 5 to 8m<sup>2</sup> per litre. Apply with brush or roller.

### Application over Butynol

Clean old Butynol surface thoroughly with sugar soap (trafficable areas need a further wipe using Ardex WA98 solvent). Apply one coat of Ardex Bonding Primer to the cleaned membrane surface at an approximate rate of 6m<sup>2</sup> per litre. Apply with brush or roller. Wait for primer to dry before applying Ardex Tufftex.

No primer required if applied over new Sheltercoat.

### Application

Apply with a brush, hopper spray, long nap or texture roller. Ensure the coating is applied evenly at the recommended coverage rates.

## PACKAGING

20L PVC Pails.

## COVERAGE

Apply two coats to ensure a finished coverage of 1.0 litres per square metre.

## CLEAN UP

Clean all equipment in fresh water before hardening commences. Remove cured material with mineral turps.

## STORAGE

Ardex Tufftex must be stored above 6°C.

## SHELF LIFE

One year in unopened containers stored at 20°C.

## SAFETY DIRECTIONS

Avoid contact with skin and inhalation of the vapour. Provide adequate ventilation. Keep out of reach of children. If swallowed contact a doctor or Poisons Information Centre.

Contact Ardex for specific applications and material safety data sheet.



---

# ARDEX WPM 265

**Sheltercoat Water Based Primer**

---

# ARDEX WPM 265

## Sheltercoat Water Based Primer

---

### DESCRIPTION

Ardex WPM 265 (Sheltercoat Water Based Primer) is a red pigmented, acrylic primer system which creates a positive bond between the substrate and most water based coatings. Designed principally for internal use, Ardex WPM 265 (Sheltercoat Water Based Primer) can also be used for external applications

### TYPICAL APPLICATIONS

- New and old concrete
- Timber
- Compressed fibreboards
- Primer for acrylic coatings

### APPLICATION REQUIREMENTS

#### Substrate preparation

The surface to be coated should be dry, clean, sound and free from oil, grease and flaking paint. New concrete should be left a minimum of 28 days and new render a minimum of 7 days before application commences. All cracks or holes exceeding 2mm are to be repaired before application commences.

#### Application

Apply with brush, long nap roller or conventional spray. Ensure that the coating is applied evenly at the recommended coverage rates. Allow a drying time of at least one hour.

### LIMITATIONS

Do not apply Ardex WPM 265 (Sheltercoat Water Based Primer) if the temperature is below 10°C or above 35°C.

Primed surfaces should preferably be overcoated within the same day of application to avoid intercoat contamination.

### COVERAGE

Approximately 6m<sup>2</sup>/litre. Coverage rate may vary depending on the porosity of the surface.

### PACKAGING

20L PVC Pails.

### CLEAN UP

Clean all equipment in fresh water immediately after use.

### SHELF LIFE

One year in unopened containers stored at 20°C.

### STORAGE

Ardex WPM 265 (Sheltercoat Water Based Primer) must be stored above 6°C.

### SAFETY DIRECTIONS

Avoid contact with skin and inhalation of the vapour. Provide adequate ventilation. Keep out of reach of children. If swallowed contact a doctor or Poisons Information Centre.

Contact Ardex for specific applications and material safety data sheet.



---

# ARDEX WPM 270

**Sheltercoat Solvent Based Primer**

---

# ARDEX WPM 270

## Sheltercoat Solvent Based Primer

---

### DESCRIPTION

Ardex WPM 270 (Sheltercoat Solvent Based Primer) is a clear primer designed to lock particles on the substrate to achieve maximum adhesion for subsequent coatings. It has excellent durability and is a low viscosity binder that seals absorbent substrates and penetrates dust. Designed principally for external applications, care should be taken when using internally to ensure adequate ventilation exists during application.

### TYPICAL APPLICATIONS

- New and old concrete
- Timber
- Compressed fibreboards
- Primer for acrylic coatings

### BASIC APPLICATION REQUIREMENTS

#### Substrate preparation

The surface to be coated should be dry, clean, sound and free from oil, grease and flaking paint. New concrete should be left a minimum of 28 days and new render a minimum of 7 days before application commences. All cracks or holes exceeding 2mm are to be repaired before application commences.

#### Application

Apply with brush, long nap roller or conventional spray at a coverage rate of 6m<sup>2</sup>/litre. Ensure that the coating is applied evenly at the recommended coverage rates. Allow a drying time of at least one hour.

### LIMITATIONS

Do not apply Ardex WPM 270 (Sheltercoat Solvent Based Primer) if the surface temperature is below 5°C or above 35°C.

Surfaces must be dry prior to application.

Primed surfaces should preferably be overcoated within the same day of application to avoid intercoat contamination.

### COVERAGE

Approximately 6m<sup>2</sup>/litre. Coverage rate may vary depending on the porosity of the surface.

### PACKAGING

20L Metal Pails.

### CLEAN UP

Clean all equipment in general purpose thinners immediately after use.

### STORAGE

Ardex WPM 270 (Sheltercoat Solvent Based Primer) must be stored above 6°C.

### SHELF LIFE

One year in unopened containers stored at 20°C.

### SAFETY DIRECTIONS

Avoid contact with skin and inhalation of the vapour. Provide adequate ventilation. Keep out of reach of children. If swallowed contact a doctor or Poisons Information Centre.

Contact Ardex for specific applications and material safety data sheet.



---

# ARDEX Superflex Primer

---

Water Based Primer

# ARDEX Superflex Primer

## Water Based Primer

### PRODUCT DESCRIPTION

Ardex Superflex Primer is a red water based acrylic primer designed to seal the substrate and enhance the adhesion qualities of Ardex Superflex waterproofing membranes. The distinctive colour makes it easy to identify when the primer has been applied. Ardex Superflex Primer is fast drying, non-toxic and can be used on a wide variety of substrates.

### FEATURES/BENEFITS

- Promotes bonding between membrane & substrate
- Suitable for most substrates
- Easy application and cleaning
- Primed surfaces are easily identified

### RANGE OF APPLICATION

A heavy duty water based primer formulated to penetrate and seal absorbent surfaces making them a sound base for waterproofing. For commercial and residential use, both internal and external.

#### Surfaces

Walls and floors

#### Substrates

Fibre cement sheets

Plywood (structural PAA and marine)

Particle board (wet area)

Concrete, renders and screeds

Masonry and concrete blocks

Plasterboard surfaces do not require priming

### SURFACE PREPARATION

Ensure that the surface to be primed is free from loose materials, dust, oil, paint, curing compounds and any other contaminating materials. Remove laitance and roughen dense concrete by mechanical means.

### APPLICATION

Apply one coat of the primer by brush, roller, conventional or airless spray over entire area to be waterproofed including cracks. If the substrate is porous, a second coat may be required. Allow primer to dry before applying Superflex waterproofing membrane.

### MIXING

Not required. Do not add water or other materials to the primer.

### COVERAGE

One (1) litre will cover approximately 6 square metres. Coverage will vary depending on the porosity of the surface.

### DRYING TIME

Touch dry in around 20-30 minutes, at 23°C, 50% RH. Drying time will vary depending on humidity, temperature and surface porosity. Important: Ardex Superflex Primer must be dry prior to the application of the Ardex Superflex membrane.

### CLEANING

Wash brushes and rollers with clean water.

### PRECAUTIONS

- Do not apply when surface temperature is outside range 5-30°C.
- Do not use on glazed, impervious or silicone treated surfaces.
- Metal surfaces must be primed with an appropriate metal primer.
- Do not empty excess primer back into original pack as this may cause contamination.
- Highly dense or steel trowelled substrates may require Ardex Superflex Solvent Based Primer to achieve optimal adhesion.
- For substrates other than those listed contact Ardex.

### SAFETY DATA

Ardex Superflex Primer-water based is non-toxic. However, the contents should not be swallowed or inhaled. In case of eye contamination, rinse thoroughly with clean water. If irritation continues seek medical advice.

### PACKAGING

20kg (1kg is equal to approximately 0.97 litres)

### STORAGE

Ardex Superflex Primer has a 12 month shelf life when stored in the original unopened packaging, in a dry place at 23°C, 50% RH.

### QUALITY PRODUCT

Ardex Superflex Primer- water based is manufactured and tested to Ardex procedures which are maintained in accordance with Quality System Standard ISO 9001. Material Safety Data Sheets are available from Ardex upon request.

---

## USER NOTES

The technical details and recommendations contained in this data sheet are given in good faith and represent the best of our knowledge and experience at the time of printing. It is responsibility of the user to ensure that the product is used in accordance with Ardex instructions and in applications for which they are intended.

## TECHNICAL DATA

### Product Identity

Form:	one part, acrylic based liquid
Dried Colour:	red
Specific Gravity:	approx 1.03
pH:	8 - 9

### Application Properties

Drying Time:	20 - 30 minutes @ 23°C, 50% RH
Coverage:	6m <sup>2</sup> /litre
Method:	roller, brush, conventional or airless spray





---

# ARDEX WPM 256

## HydrEpoxy 256 Bonding Bridge

---

Water Based Epoxy Bonding Bridge

# ARDEX WPM 256

## HydrEpoxy 256 Bonding Bridge

## Water Based Epoxy Bonding Bridge

### PRODUCT DESCRIPTION

Ardex WPM 256 (HydrEpoxy 256) is a two component water based epoxy polyamide unpigmented new to old concrete bonding bridge and admixture for cement based materials.

- Non-flammable and negligible odour
- Convenient equal part-mixing ratio
- Surface tolerant
- Water thinned and clean up

### FEATURES/BENEFITS

A relatively high solids product specifically designed as a high strength bonding bridge for bonding new render or concrete to aged concrete substrates. Ardex WPM 256 (HydrEpoxy 256) is also used as an epoxy admixture for cementitious products used for concrete repair.

- Forms a structural bond between new and old concrete
- Can be applied to damp surfaces
- Is compatible with fresh cement or concrete products
- Has excellent adhesion to most substrates including brick, masonry, concrete block, concrete, compressed fibreboard, stone and timber

### TYPICAL APPLICATIONS

- As a new to old concrete bonding bridge to substantially improve the bonding characteristics
- As an admixture to cement to produce variable strength repair mortars and waterproofing grouting material
- As a concrete curing membrane to contain the water and as an aid to the curing of and sealing of concrete

### LIMITATIONS

The product should be applied whilst the surface temperature is between 10-35°C. The product will cease to cure below 10°C, but will recommence curing when the temperature rises above 10°C. Curing time will also be adversely affected in situations where relative humidity is >85%.

Good ventilation should be provided during curing cycle.

Will yellow when exposed to ultra violet light for extended periods.

The cured coating will form a glazed chemically resistant surface finish which must be well sanded to produce a coarse surface profile prior to adhering any product to the cured film.

### BASIC APPLICATION INSTRUCTIONS

#### Surface preparation

All surfaces to be treated must be structurally sound, all previous coatings should be removed and the surface cleaned free from contaminants.

#### Installation

Each component should be individually mixed to form homogeneous components. Thoroughly mix the two components in the ratio of 1:1 by volume, preferably using a power stirrer, until a homogeneous mix is obtained. Only mix as much as may be used within the pot life of the product and avoid excessive aeration during mixing.

#### Application as a new to old concrete bonding bridge

Apply one coat by brush, roller or spray to a section of the area to be treated at a coverage rate of 7m<sup>2</sup>/litre.

Only apply the Bonding Bridge to an area to which the new render or concrete can be placed while the bonding bridge remains wet or tacky.

Immediately following application of the Ardex WPM 256 (HydrEpoxy 256), place the new render or concrete and finish as required.

Repeat the process until the full area to be treated is complete.

#### Application as a concrete repair mortar

After mixing the Ardex WPM 256 (HydrEpoxy 256), mix with an equal volume of cement and add a fine particle grade river washed sand to achieve the desired working consistency (normally 2-3 times the volume of cement added).

During trowel finishing of the concrete repair mortar, use a wet trowel to avoid drag-up and to obtain a smooth finish.

#### Application as a concrete curing membrane

Apply one coat by brush, roller or spray at a coverage rate of 3m<sup>2</sup>/litre.

Note that surfaces must be sanded in the event of application of coatings or adhesives after the film has cured.

### SAFETY DATA

UN Number: N/A - non-flammable and non explosive

Inhalation: Non toxic, irritating or flammable vapour

Ardex WPM 256 (HydrEpoxy 256) may cause a mild dermatitis skin reaction with some people after prolonged contact. It is recommended that protective gloves be used during application.

## CLEAN UP & DISPOSAL

Thinning should be carried out in accordance with the usage data contained in the table below.

Wash all equipment in water or water/detergent immediately on completion of work since Ardex WPM 256 (HydrEpoxy 256) will cure underwater if equipment is left.

## TECHNICAL PERFORMANCE DATA

In each of the applications below mix part A and part B of the Ardex WPM 256 (HydrEpoxy 256) at a ratio of 1:1 by volume, prior to adding other components.

Typical Sealer Application	Bonding	Concrete Agent	Concrete repair mortar*	Concrete curing membrane	Cement paint
Mixture (by vol)					
Ardex WPM 256 (A:B)	100	100	100	100	100
Water	50	0-10		50	0-25
Cement		100		100	
Sand				0-300	
No. of coats	2	1	N/A	2	2
Coverage of Binder 256 before dilution					
(The figures in brackets indicate coverage achieved once all components have been added together.)					
m <sup>2</sup> /ltr/coat	8 (5.3)	5 (4.5)	N/A	7 (4.7)	4
6mm topping			0.6	N/A	N/A
Pot life @ 25°C (hrs)	1½	1½	¾	1½	¾
Cure time @ 25°C	Touch dry-4hrs; Hard dry-24 hrs; Full cure-7 days				

\* A waterproof grout can be similarly formulated using 100 parts by volume of sand.





---

# ARDEX WPM 300

**HydrEpoxy 300**

---

Water Based Epoxy Membrane

# ARDEX WPM 300

## HydrEpoxy 300

### Water Based Epoxy Membrane

#### PRODUCT DESCRIPTION

Ardex WPM 300 (HydrEpoxy 300) is a two component water based epoxy polyamide membrane/barrier coating.

Approved for use with potable (drinking) water, independent testing confirms conformity with the requirements of:-

#### FEATURES/BENEFITS

- Non-flammable & negligible odour.
- Can be applied to damp surfaces.
- Can be safely applied to freshly laid hardened (green) concrete.
- Conforms to requirements of the:-  
**Australian Building Code**  
as a waterproofing membrane.
- Conforms to the requirements of AS4020 and BS6920 for use in contact with potable water.  
**Australian standard 4020 - 2000**  
and **British Standard 6920**
- When applied directly to the substrate the cured membrane will withstand 250kPa hydrostatic pressure which is equivalent to a 25 metre head of water.
- When used wet on wet over Ardex WPM 200 (HydrEpoxy 200) the cured membrane will withstand 400kPa pressure which is equivalent to 40 metre head of water.
- No maximum recoat time provided surface is clean and free from surface contaminants.
- Can be overcoated using almost any decorative or industrial finishing paint.
- Safe to use in sensitive locations (e.g. around food or habitable areas) and environmentally friendly.
- Prevents rising damp and the formation of efflorescence when used as a single coat barrier coat.
- Has excellent adhesion to most substrates including brick, masonry, concrete block, concrete, stone and timber.
- Easy clean-up using water.

#### TYPICAL APPLICATIONS

- As a low water vapour transmission coating in the building and construction industries and as a barrier/seal coating over freshly laid or damp concrete.
- As a hydrostatic pressure resistant waterproofing membrane to prevent water seepage or dampness penetration through to the interior of walls and floors.

- As a waterproofing barrier on the negative side in below grade surfaces such as basements, tunnels, liftwells, retaining walls and carparks.
- As a waterproofing membrane or barrier coating over freshly laid hardened (green) concrete, prior to the application of conventional carpet and tile adhesives.
- As a waterproofing membrane in tanking applications, including potable water containment.
- As a barrier seal coating over damp, green or efflorescence producing concrete prior to overcoating with conventional building paints.

#### LIMITATIONS

The product should be applied whilst the surface temperature is between 10-35°C. The product will cease to cure below 10°C, but will recommence curing when the temperature rises above 10°C. Curing time will also be adversely affected in situations where relative humidity is >85%.

In enclosed areas, ventilation must be provided during curing cycle to enable adequate evaporation of the water.

Care should be taken when sandwiching adhesives between Ardex WPM 300 (HydrEpoxy 300) and floor coverings to ensure the water vapour transmission of the covering is sufficient to allow the solvent to escape.

Ardex WPM 300 (HydrEpoxy 300) is not classified as a trafficable membrane.

#### BASIC APPLICATION INSTRUCTIONS

##### Surface preparation

All surfaces to be treated must be structurally sound; and existing coatings, adhesives, efflorescence should be removed to achieve maximum bond strength and resistance to hydrostatic pressure. Surfaces must be cleaned from dirt, grease, oil, or other surface contaminants.

Holes, non-structural cracks or other surface deformities should be filled with either an Ardex WPM 405 (Sheltercrete Additives) or epoxy mortar and allowed to cure for 2-3 hours before coating is applied.

##### Installation

Each component should be individually mixed to form a homogenous component.

Thoroughly mix the two components in the ratio of 1:1 by volume until a homogeneous blend is obtained. Only mix as much as may be used within the pot life and avoid excessive aeration during mixing.

When the product is to be applied to dry concrete it is advisable to wet the surface with a fine mist of water before application.

Floors-Spread the material using a squeegee or stiff

nylon broom to achieve coverage and finish using a long nap roller.

**Walls**-Apply the product by roller or spray taking care to achieve required coverage.

Care must be taken to work the material into the surface to fill voids and avoid pinholing. A minimum of two coats is recommended and care should be taken to ensure uniformity of material and the required coverage is maintained. When finishing it is necessary to lay the material onto the surface and lightly finish to achieve the required dry film thickness per coat.

The coverage rate for all surfaces should be a total of 1.5 square metres per litre ( 3.0 square metres per litre per coat) to achieve optimum properties. In the event that this coverage rate is not achieved in two coats, further coats should be applied to achieve a total uniform coverage rate of 1.5 square metres per litre.

Allow to cure for 24 hours before applying adhesives, mortars, decorative coatings or other surface treatments. Care is necessary to ensure the waterproofing membrane coating is not damaged in any way during subsequent treatments.

It is recommended that the final coating applied to floor surfaces should be allowed to cure for at least 3 days before further treatment to minimize the risks of mechanical damage.

#### **SAFETY DATA**

All epoxy materials can cause irreversible skin sensitisation with some people following regular skin contact. It is strongly recommended that protective clothing is worn at all times during use of epoxy material to prevent contact with the skin.

UN Number: N/A non flammable and non explosive. Non toxic, irritating or flammable vapour when used according to the instructions. May be irritating and cause sensation by skin contact and be irritating to the eyes on contact. Wear suitable gloves and eye/face protection during mixing and application, avoid contact with skin and eyes. In the event of contact, wash immediately with soap and water.

Refer to the material safety data sheet for further information.

#### **CLEAN UP & DISPOSAL**

The first coat should be thinned with water, as required depending on the porosity of the surface to be coated (up to 20% for dense surface to 5% for more porous surfaces) to ensure optimum penetration. Thinning of the second coat should be avoided since this increases the difficulty in achieving the required dry film thickness. Wash all equipment in water or water/detergent immediately on completion.

#### **TECHNICAL PERFORMANCE DATA**

Colour	Grey, Black
Finish	Semi-gloss going to matt with aging
Volume solids	44%
Mixing ratio	1:1 (Part A:/Part B) by volume
	Coverage Must be applied at a rate of 1.5 square metres per litre to achieve an effective waterproofing membrane. Minimum two coats are recommended to achieve uniform coverage.
Wet Film Thickness	300 microns per coat
Recoat time	2 hours @ 25°C, 50% RH
Full cure	7 days @ 25°C, 50% RH
Pot life	2 hours @ 25°C 1 hour @ 35°C

The recommended wet film thickness specified produces a nominal dry film thickness of 150 microns per coat or 300 microns for two coats. The apparent dry film thickness will reduce depending on the porosity of the substrate, however the product absorbed by the substrate forms part of the waterproofing function.





---

# ARDEX WPM 501

**HydrEpoxy 501**

---

# ARDEX WPM 501

## HydrEpoxy 501

### PRODUCT DESCRIPTION

Ardex WPM 501 (HydrEpoxy 501) is a two component water based epoxy high-bodied polyamide environmentally friendly adhesive.

### FEATURES/BENEFITS

- Easy clean up using water
- Can be applied to damp surfaces
- Cures underwater in fresh, chlorinated and salt waters
- Resistant to fresh, chlorinated or salt waters
- Can be applied to freshly laid (green) concrete
- Non-flammable, very low odour and toxicity
- Can be applied to interior or exterior surfaces
- May be used as an admixture with cement to form a patching mortar
- Has excellent adhesion to most substrates including brick, masonry, concrete block, concrete, compressed fibre board, PVC, rubber, surface wallboards and timber, including parquetry

### TYPICAL APPLICATIONS

- As a waterproof structural adhesive for wet areas
- As a waterproof adhesive in the bonding of floor and wall coverings such as Versilux or Hardiflex
- As a waterproof adhesive in the bonding of flashings such as hypalon or butyl rubber, fibre cement, rigid PVC or galvanised surfaces
- As a waterproof high strength adhesive in the wet or damp, edge or face bonding of Compressed Fibre Board or Sheet
- As a sandable filler over recessed fixing screws or surface imperfections

### LIMITATIONS

Do not use in contact with uncoated steel - Consult Ardex in regard to other metals and alloys.

The product should be applied whilst the surface temperature is between 10-35°C. The product will cease to cure below 10°C, but will recommence curing when the temperature rises above 10°C. Curing time will also be adversely affected in situations where relative humidity is >85%.

The addition of cement will significantly reduce the working pot life.

Ardex WPM 501 (HydrEpoxy 501) is a semi rigid adhesive and should not be used where expansion and contraction is expected.

### BASIC APPLICATION INSTRUCTIONS

#### Surface preparation

All surfaces to be treated must be structurally sound, existing coatings, adhesives, efflorescence should be removed. Surfaces must be cleaned from dirt, grease, oil, or other surface contaminants.

Holes, non-structural cracks or other surface deformities should be primed with Ardex WPM 501 (HydrEpoxy 501) thinned with water and filled with a mortar prepared from 1 part cement, 2 parts sand and 1 part Ardex WPM 501 (HydrEpoxy 501) and allowed to cure for 2-3 hours (pot life is reduced when mixed with cement).

#### Installation

Each component should be mixed to redisperse any liquid and to form a smooth uniform paste.

Thoroughly mix the two components in the ratio of 1:1 by volume until a homogeneous paste is obtained. Only mix as much as may be used within the pot life of the product.

When bonding compressed sheet, butter the adhesive onto both edges and push together gently until the glue line thickness is 1mm (i.e. the edges of the board are separated by 1mm of adhesive)

For bonding wall coverings and other broad span surfaces, apply the Ardex WPM 501 (HydrEpoxy 501) using a medium saw tooth notched trowel to the substrate only and press the covering material into the adhesive. Ensure the entire surface is coated with the adhesive to ensure maximum bond strength. The size of the notch trowel will depend on substrate and the profile of the material to be bonded. Peaks of adhesive should be able to be compressed by 2-3mm when bonding.

When bonding flashings apply Ardex WPM 501 (HydrEpoxy 501) with a notched trowel or glue spreader to the substrate surface only. Lay the flashing immediately onto the adhesive and press firmly into position. Remove all excess with a damp sponge.

### SAFETY DATA

UN Number N/A non flammable and non explosive

Non toxic, non irritating or flammable vapour.

May cause a mild dermatitis skin reaction with some people after prolonged contact. It is recommended that protective gloves be used during application.

### CLEAN UP & DISPOSAL

Ardex WPM 501 (HydrEpoxy 501) should not be thinned when used as an adhesive.

Wash all equipment in warm water or water/detergent immediately on completion of the work.

---

### TECHNICAL PERFORMANCE DATA

Colour	Grey
Volume solids	52%
Mixing ratio	1:1 (Part A/Part B) by volume
Coverage	Full cover (with notched trowel) 2m <sup>2</sup> /litre (note: coverage will vary depending on substrate)
Hard time	24 hours @ 25°C, 50% RH
Full cure	7 days @ 25°C, 50% RH
Pot life	2 hours @ 25°C 1 hour @ 35°C





---

# ARDEX WPM 900

**HydrEpoxy 900**

---

# ARDEX WPM 900

## HydrEpoxy 900

### PRODUCT DESCRIPTION

Ardex WPM 900 (HydrEpoxy 900) is a two component acrylic modified epoxy enamel & anti-graffiti coating.

- Resists mildew, mould and bacteria growth
- Withstands regular steam cleaning and high pressure water washing
- Aged coating may be recoated with minimal surface preparation
- Easy graffiti removal from cured finish (over smooth surfaces)
- Available in a selected range of colours

### FEATURES/BENEFITS

A decorative, hard wearing impermeable finish coating that can be applied to damp surfaces and is subsequently easily recoated. Safe to use in sensitive locations (e.g. around food areas)

- Long pot life
- Easy clean up using water/detergent
- Can be used successfully as a wall, ceiling and floor surface coating
- Can be applied over most existing coatings.
- Non-flammable, negligible odour and toxicity.
- Has excellent adhesion to most substrates including brick, masonry, concrete block, concrete compressed fibreboard, stone and timber
- Suitable for use in fire escapes

### TYPICAL APPLICATIONS

- As a low odour very hard wearing and chemically resistant finish coating for industry, commercial and hygiene areas subjected to rigorous cleaning or high wear
- As an abrasion and chemical resistant floor coating with or without non-skid properties
- As an anti-graffiti coating for high traffic areas such as railway stations, carparks, etc
- As a mould and bacteria resistant hard finish for wash rooms, shower cubicles, canteen areas and food preparation areas
- As a high performance new construction or maintenance coating in food industries such as abattoirs, dairies, canneries, wineries

### LIMITATIONS

The product should be applied whilst the surface temperature is between 10-35°C. The product will cease to cure below 10°C, but will recommence curing when the temperature rises above 10°C. Curing time will also be adversely affected in situations where relative humidity is >85%.

In enclosed areas ventilation should be provided during the application and curing cycle to enable adequate evaporation of the water

Do not apply to alkaline surfaces or thin with alkaline water

### BASIC APPLICATION INSTRUCTIONS

#### Surface Preparation

All surfaces to be treated must be thoroughly cleaned free from all loose or flaking paint and must be free of grease, oil, dirt, dust or other surface contaminants.

Any efflorescence or laitance must be removed from new concrete by abrasive blast cleaning, high pressure water washing or mechanical scrubbing. Acid etching should be avoided due to the risk of chlorine penetration and should only be used on overworked steel trowelled finishes where a cement rich surface has been obtained. Note new concrete should be allowed to cure for 21 days or primed with Ardex WPM 256 (HydrEpoxy 256) prior to coating application.

#### Installation

Each component should be thoroughly mixed ensuring the mixer tools are clean prior to use with each component.

For best results the Ardex WPM 900 (HydrEpoxy 900) should be thinned with 5-7% methylated spirits (or 10% with water if solvents not permitted) before use.

Thoroughly mix the two components in the ratio of 4:1 (A:B) by volume using a power stirrer until a homogeneous mix is obtained.

Apply using a brush, roller or spray. A minimum of two coats is recommended for optimum results.

### SAFETY DATA

UN Number N/A non flammable and non explosive.

Product should only be applied under conditions of good ventilation and should be kept away from sensitive areas of the body as prolonged exposure may cause skin and/or respiratory irritation.

Fire Rating (AS 25.30.3.1989)

Ignitability index =0

Spread of flame index =0

Heat evolved index =0

Smoke developed index =3

---

## CLEAN UP & DISPOSAL

Thinning may be carried out using water or methylated spirits as described above.

Wash all equipment in water or water/detergent immediately on completion of the work.

## TECHNICAL PERFORMANCE DATA

Colour	White, grey and selected standard colours
Finish	Gloss which reduces with aging
Volume solids	35±2%
Mixing ratio	4:1 (Part A/Part B) by volume
Typical coverage	7.0 m <sup>2</sup> /ltr @ 50 µm d.f.t 4.7 m <sup>2</sup> /ltr @ 75 µm d.f.t
Touch dry time	4-6 hours @ 25°C, 50% RH
Recoat time	6-8 hours @ 25°C, 50% RH
Full cure	7 days @ 25°C, 50% RH
Pot life	8 hours @ 25°C 6 hours @ 35°C





---

# ARDEX WPM 163

**Single Component PU Acrylic Sealer**

---

# ARDEX WPM 163

## Single Component PU Acrylic Sealer

### PRODUCT DESCRIPTION

Ardex WPM 163 is a single component water based urethane modified acrylic water resistant protective sealer that penetrates and cures within the pores of the surface being sealed. Ardex WPM 163 is semi permeable allowing the surface to breathe and is not a waterproof membrane to resist ponding water.

### USES

#### Dust suppressant

Single component sealer and dust suppressant for warehouse and showroom concrete floors.

#### Oil and petrol resistant

For driveways, motor vehicle service bays and garage floors.

#### Water resisting sealer

For concrete, roof tiles, brick, stone, slate and masonry to inhibit water penetration.

#### Protective sealer

For sandstone to minimize dirt and atmospheric grime from developing and allowing the sandstone to breathe.

#### Wall panelling sealer

For wall panelling enabling a surface finish ranging from matt to gloss depending on the number of coats applied.

### FEATURES

- Interior or exterior use.
- Water white and stable to ultra violet discolouration.
- Requires only short downtime for application. Four coats can be applied within the same day allowing light pedestrian traffic within 24 hours.
- Penetrates and cures within the pores of the surface being sealed to provide extended service life.
- Provides high abrasion resistance since the wear properties are dependent on the base substrate.
- Excellent petrol and oil resistance.
- Can be recoated at any time.
- Good flexibility properties to withstand substrate expansion and contraction.
- Can be applied by brush, roller or spray application.
- Can be applied to damp surface and freshly laid concrete.
- Non-flammable and very low odour.
- Surface tolerant and flexible.

### TECHNICAL DATA

Colour	Clear/water white
Finish	Semi-gloss going to mat with external exposure aging
Typical coverage	15m <sup>2</sup> /ltr per coat after thinning depending on the porosity of the substrate
Typical no. of coats	2-4 depending on the substrate porosity & surface finish desired
Recoat time	30 min to 1 hour @ 25°C, 50% R.H.
Full cure	7 days @ 25°C, 50% R.H.
Ultra violet resistance	Excellent



## **Australia**

### **New South Wales**

20 Powers Road, Seven Hills, NSW 2147

Phone 02-9851 9199, Fax 02-9674 5621

### **Queensland**

Phone 07-3881 3888, Fax 07-3881 3188

### **Victoria/Tasmania**

Phone 03-9308 9255, Fax 03-9308 9332

### **South Australia**

Phone 08-8268 2511, Fax 08-8345 3207

### **Western Australia**

Phone 08-9455 1644, Fax 08-9455 1227

## **New Zealand**

### **Christchurch**

32 Lane Street, Woolston, PO Box 19549

Phone 03-384 3029, Fax 03-384 9779

### **Wellington**

Phone 04-568 5949, Fax 04-568 6376

### **Auckland**

Phone 09-580 0005, Fax 09-579 9963

[www.butynol.co.nz](http://www.butynol.co.nz)

[www.ardex.com](http://www.ardex.com)