



ARDEX WPM 001

Superflex Bathroom & Balcony Premixed - 1 Part

Single Component Undertile Waterproofing Membrane

BRANZ Appraised

Low VOC content – meets Green Building Council of
Australia Green Star IEQ-13 requirements

Fast drying one part acrylic membrane

ARDEX WPM 001

Superflex Bathroom & Balcony Premixed - 1 Part Undertile Waterproofing Membrane



Copies available on request.

PRODUCT DESCRIPTION

Ardex WPM 001 (Superflex Bathroom & Balcony Premixed 1 Part) is a tough, ready to use waterproofing membrane specifically designed for use under tiles. Ardex WPM 001 has been uniquely formulated with synthetic microfibres to increase its strength and eliminate the need for a separate reinforcement mat. Ardex WPM 001 is based on the most advanced acrylic polymer technology, and is totally resistant to re-emulsification once cured.

Ardex WPM 001 is flexible, safe to use, low in odour, and is fully compatible with polymer modified tile adhesives. Ardex WPM 001 is one of the fastest drying one part acrylic membranes on the market – normally ready to tile in 48 hours @ 23°C.

WPM 001 meets the Green Building Council of Australia Green Star IEQ-13 requirements for Architectural Sealant when tested in accordance with SCAQMD Method 304-91 Determination of Volatile Organic Compounds (VOC) in Various Materials as referenced by South Coast Air Quality Management Division (SCAQMD) Rule 1168.

FEATURES/BENEFITS

- Fast drying Ardex WPM 001 can be tiled over in 48 hours in non critical areas*
- Liquid reinforced: Excellent strength, eliminates need for reinforcing mat
- Flexible: Accommodates normal building movement class 3 membrane as per AS/NZ 4858: 2004 Wet Area Membranes
- Advanced acrylic: Will not re-emulsify once cured
- Designed for tiling - Fully compatible with Ardex tile adhesive systems
- Water based, safe to use, low odour & easy cleaning
- CSIRO Appraisal #91 for undertile waterproofing in shower recesses
- Conforms to the requirements of AS/NZ 4858: 2004 Wet Area Membranes. (Ref: CSIRO Report 3779)

*Critical areas include areas where the membrane is applied at greater than 0.5mm or over impermeable substances such as over bond breakers or incorporating other reinforcement. Longer drying times are necessary in these areas.

APPLICATION RANGE

Performance Levels

Commercial and residential

Location

Internal wet areas, balconies, decks, and other areas that will be tiled or otherwise protected from regular foot traffic.

Surfaces

Walls & floors

Substrates

Concrete	Cured for min. 28 days or sealed when set with one coat of Ardex WPM 300 (HydrEpoxy 300) at a coverage rate of 3.0 square metres per litre and allowed to cure overnight. External wet concrete should be allowed to dry thoroughly or sealed with one coat of Ardex WPM 300 as above.
Renders and screeds	Cured for min. 7 days or sealed when set with one coat of Ardex WPM 300 at a coverage rate of 3.0 square metres per litre and allowed to cure overnight. Wet render should be allowed to dry thoroughly or sealed with one coat of Ardex WPM 300 as above.
Fibre cement	Suitable for wet area grade fibre cement.
Plasterboard	Wet area grade only.
Plywood	Structural plywood (PAA branded), marine grade or other wet area grade only.
Particleboard	Wet area grade, internal use only (special preparation is required – contact Ardex).
Permanent Immersion	In conditions of permanent immersion, it is recommended that Ardex WPM 002 (Superflex Two Part) is used. Must be covered with tiles for full immersion.

Contact Ardex for use over existing membranes, covering materials, and any other substrates not listed.

SPECIFICATION CLAUSE

ARDEX WPM 001 (Superflex Premixed)

The waterproofing membrane shall be Ardex WPM 001: a one part acrylic modified fibre reinforced membrane formulated to provide a tough, long lasting water barrier under tiling systems.

PACKAGING

Single component: 20kg (approx 15 litres) or 6.5kg (approx 5 litres).

TABLE 1

	Thickness per Coat		Total Dry Film Thickness (2 coats)	Theoretical Coverage		Per Unit
	Dry Film	Wet Film		Per coat	For 2 coats	
FLOORS	0.5mm	1.0mm	1.0mm	15m ²	7.5m ²	20kg(15L) unit
WALLS	0.25mm	0.5mm	0.5mm	30m ²	15m ²	20kg(15L) unit

SHELF LIFE

12 months when stored in the original unopened packaging, in a dry place at 23°C. Do not store in direct sunlight. Replace lid tightly after use. Use remaining contents from part used containers within 3 months.

COVERAGE

Two coats are recommended for an effective waterproof membrane.

Coverage will vary depending on the porosity of the surface.

One 20kg (15 litre) unit will cover approximately 7.5-15m² (based on two coats) depending on area requirements between wall and floor surfaces to be treated. Refer Table 1.

DRYING TIMES

Recoat time

1-2 hours at (23°C/50% RH) between first and second coats. Alternatively, if a polyester mat is used between coats then the second coat can be applied whilst the first coat is still wet.

Dry through

The slowest drying areas are those where the membrane has been applied over a silicone bond breaker, eg. wall and floor junctions. The membrane cannot be tiled over until these critical areas are completely dry. Ardex WPM 001 is totally dry in 48 hours at 23°C/50% RH, but can take up to 72 hours at 10°C/50% RH in corners or for thick films.

Fully cured

The shower should not be used until the membrane has reached its full strength. Ardex WPM 001 membrane is fully cured after 3 days at 23°C, or after 5 days at 10°C.

Drying times will vary depending on humidity, surface temperature and surface porosity.

Do not apply on substrates where the surface temperature is below 10°C or above 35°C.

CLEANING

Wash hands, brushes, rollers, etc, with water while the membrane is still fresh. Remove cured material with mineral turpentine.

SAFETY PRECAUTIONS

Do not use the product in the following situations:

- Areas subject to negative hydrostatic pressure or rising damp, unless treated with Ardex WPM 300.
- Where the substrate is wet – wet surfaces can be sealed with one coat of Ardex WPM 300 at a coverage rate of 3.0 square metres per litre and allowed to cure overnight.
- Where rain is imminent.
- Where the membrane will be left exposed and subjected to regular foot traffic.
- On glazed, glass or other totally impervious surfaces (eg. areas pre-treated with water repellants).
- Where the surface temperature is below 10°C or greater than 35°C.
- All floor areas must have adequate falls either built into the substrate or achieved with a sand/cement screed prior to application of the Ardex WPM 001.

For substrates or situations other than those listed contact Ardex.

SAFETY DATA

Ardex WPM 001 is non-hazardous and non dangerous. It may produce discomfort of the eyes, respiratory tract and skin. Do not breathe gas/fumes/vapour/spray. Avoid contact with skin. Wear eye/face protection. In case of contact with eyes, rinse with plenty of water and seek medical advice.

ADDITIONAL INFORMATION IS LISTED IN THE MATERIAL SAFETY DATA SHEET.

QUALITY PRODUCT

Ardex WPM 001 is manufactured and tested to Ardex procedures which are maintained in accordance with Quality System Standard ISO 9001.

ARDEX WPM 001

Superflex Bathroom & Balcony Premixed - 1 Part Undertile Waterproofing Membrane

USER NOTES

The technical details and recommendations contained in this data sheet are given in good faith and represent the best of our knowledge and experience at the time of printing. It is the responsibility of the user to ensure that the product is used in accordance with Ardex instructions and in applications for which they are intended.

APPLICATION

Apply Ardex WPM 001 by brush or roller. A medium nap (12-15mm pile) paint roller is recommended. New rollers should be dampened with water before being used for the first time.

For best results with a paint brush use a good quality, 50mm long bristle variety.

To achieve the required dry film thickness per coat, application must consist of laying the product onto the surface and light finish the surface. Do not try to apply in the same manner as a building paint. A conventional building paint is normally applied at 25-40 micrometers wet film thickness while Ardex WPM 001 needs to be applied at between 0.5 and 1.0 mm per coat depending on product and application (Refer Table 1).

Critical Areas:

INTERNAL WET AREAS

1. Construction should be in accordance with Australian 3740 - 2004 Waterproofing of wet areas within residential buildings.
2. All render and tile bed requirements should be completed before application of the membrane and tiles or other floor coverings should be direct bonded to the membrane.
3. Ensure wall & floor sheets are installed as per sheet manufacturer's recommendations.
4. Ensure suitable brick/concrete hobs are used (do not use timber).

5. Ensure that falls to the waste are min 1:60 (ie. approx. 30mm in 2mtr)) before waterproofing. Ensure outlet pipes are fixed securely and that the waste or drainage flanges are recessed into the floor.
6. Avoid sheet joints in shower recess floor. Ensure that sheets are securely fixed to the wall at the bottom edge, and sheet joints are sealed with a neutral cure silicone sealant spread approximately 6mm on either side of the joint.
7. Treat nail and screw holes with neutral cure silicone sealant.
8. Seal the perimeters of taps, shower outlets and waste outlets with neutral cure silicone sealant.
9. Apply a bead of neutral cure silicone sealant to all horizontal and vertical corners.
10. Apply a bead of neutral cure silicone sealant to the junction of the hob or angle and walls. Spreading the sealant to 6mm on either side of the joint.
11. Waste outlets shall incorporate a puddle flange or similar in accordance with AS3740 & the top surface shall be set flush with the surface to which the membrane is to be applied. A bead of neutral cure silicone shall be applied across the intersection of the puddle flange and the screed/floor.
12. Apply the membrane to the entire shower recess floor and down into waste or drainage flange. Apply the membrane over the hob and at least 150mm beyond the outside edge of the hob (ideally to entire wet area floor).
13. Apply the membrane 1800mm up the walls or to the height of the shower rose within the shower recess.
14. Install the shower screen to inside edge of the hob.

Fig.1 – Shower Recess – Critical Areas

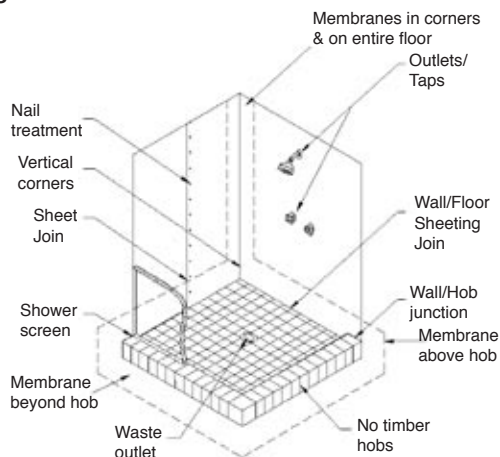
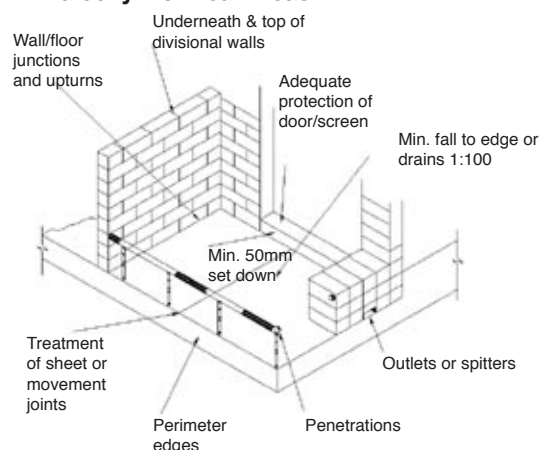

Fig.2 – Balcony – Critical Areas



BALCONIES AND DECKS

1. Ensure that the deck is constructed with falls to edge/drains of min 1:100 (ie. 20mm in 2m) or else achieve the fall with a sand/cement screed.
2. Ensure a min set down (step down) of 50mm to the finished floor level (ie. top of tiles).
3. Ensure suitable flashing is installed, ideally prior to the installation of the balcony screen/ sliding door.
4. Treat any sheet joints with a neutral cure silicone prior to waterproofing.
5. Prepare and seal all wall/floor junctions with a bead of neutral cure silicone.
6. Apply the membrane up the step down and as far up underneath the screen door flashing as possible (ideally waterproof prior to installing door).
7. Where possible, apply the membrane prior to building divisional walls, or other items such as planter boxes.
8. Apply the membrane to the entire balcony floor and at least 50mm up the wall above the top surface of the finished tiles and finished below the wall drainage vents.
9. Apply the membrane to the top of the parapets and divisional walls, or else install suitable metal capping.
10. Apply the membrane down over the front edge of the balcony onto the drip rail.
11. Carefully seal any gaps around balcony penetrations prior to applying the membrane.
12. Apply the membrane down into outlets and drains, ensuring excess material is removed.
13. Ensure all weep holes are above the membrane application area.

APPLICATION NOTES

Surface preparation

- Ensure all surfaces are structurally sound and totally dry. The pores of concrete surfaces should be open (absorbent surface). All sheet substrates must be securely fixed in accordance with the manufacturers instructions.
- Falls to outlets of at least 1:60 or approx. 30mm in 2mtr (wet areas) or 1:100 externally, must be achieved prior to tiling.
- The surface to be coated should be free from dust, oil, paint, curing compounds and any other contaminating materials.
- Damaged concrete should be repaired (leveled) and surface defects including all cracks and sharp protrusions should be treated prior to the application of the membrane.

- Remove laitance on concrete or screeds by mechanical means.
- Highly dense (>40MPa) or steel trowelled concrete should be roughened by suitable mechanical means (shot blasting, grinding, etc).

Priming

The primer is a critical part of the waterproofing system. Apply one coat of Ardex WPM 265 (Sheltercoat/ Superflex Water Based Primer) by brush or roller to all areas to be waterproofed including the floor waste. Allow the primer to completely dry prior to the application of the Ardex WPM 001 membrane. This will take around 20-30 minutes depending upon weather conditions and porosity of the substrate. Coverage is approximately 6m² per litre. Plastic (eg. PVC) pipes should be primed with a solvent based plumbers pink primer. Prime metal surfaces with a suitable metal primer such as epoxy polyamide primer.

GENERAL APPLICATION

Crack preparation

Cracks <2mm:

Clean and remove any loose particles in the crack. Prime the crack and adjacent area carefully with Ardex WPM 265 and allow to dry before applying two coats of Ardex WPM 001 membrane in a band at least 200mm wide equidistantly across the crack, along the length of the crack.

Cracks 2-6mm:

(Refer Fig. 3) Prepare and prime the crack as above. Apply a bead of neutral cure silicone into the crack and extend it 6mm either side. Apply a 300mm wide band of Ardex WPM 001 equidistantly across the crack along the entire length of the crack. Place a 190mm wide band of Ardex "Deckweb" polyester woven cloth reinforcement over the applied membrane. Thoroughly wet out the cloth preferably using a fluted roller, and remove all creases in, or air pockets under the mat. Immediately apply a second coat to completely fill the mat.

Cracks >6mm:

Contact your local Ardex representative.

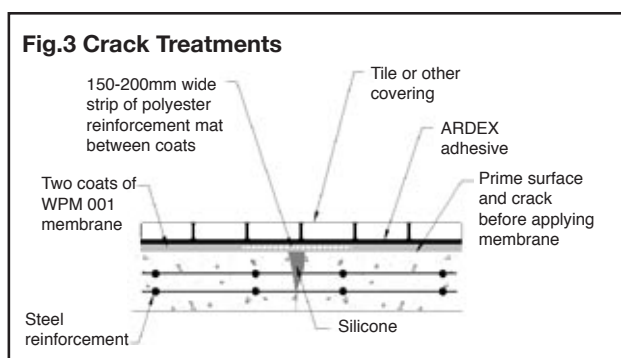

ARDEX WPM 001

Superflex Bathroom & Balcony Premixed - 1 Part Undertile Waterproofing Membrane

Movement/construction joints

Movement joints (<6mm)

Use same procedure as in crack preparation.

Clean and prime the joint before filling it with a bead of neutral cure silicone and extending it 6mm each side of joint. Apply a 300mm wide band of Ardex WPM 001 equidistantly across the crack along the entire length of the crack. Place a 190mm wide band of Ardex "Deckweb" polyester woven cloth reinforcement over the applied membrane. Thoroughly wet out the mat and remove all creases in, or air pockets under the mat. Immediately apply a second coat to completely fill the mat.

Construction joints (>6mm)

Use the same procedure as above, but replace the reinforcing mat with 120mm of Ardex Coving Bandage. Note: if tiling, movement joints should be taken to the surface of the tiles. Fill the joints between the tiles immediately above the movement joints with an appropriate joint sealant. (Refer Fig.4)

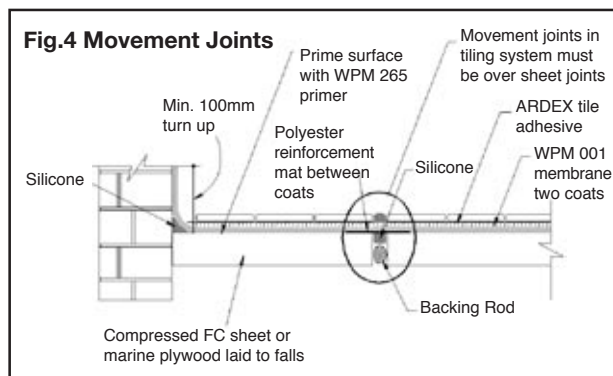

Corners & coving areas

After priming with Ardex WPM 265 and allowing to dry, apply a generous bead (12mm) of neutral cure silicone sealant to seal all junctions between two substrates in coving areas and corners. Smooth over the silicone so that it extends 6mm up the wall and 6mm over the floor and allow to touch dry.

Apply a first coat of Ardex WPM 001 to the area and allow the membrane to dry.

Apply a second coat ensuring that excess product is removed from the junction (the final dry film thickness should be minimum of 1.0mm). Alternatively, if a polyester reinforcement mat is used between coats then the second coat can be applied as soon as the mat is fully bedded into the first coat.

WALL/FLOOR JUNCTION

After priming with Ardex WPM 265 and allowing to dry, apply a generous bead (12mm) of neutral cure silicone sealant to seal all junctions between two substrates. Smooth over the silicone so that it extends 6mm up the wall and 6mm over the floor and allow to touch dry. Place a 190mm wide band of Ardex "Deckweb" polyester woven mat reinforcement over the applied membrane. Thoroughly wet out the cloth and remove all creases in, or air pockets under the mat. Immediately apply a second coat to completely fill the mat. The Ardex WPM 001 should be applied to at least 100 mm up the wall surfaces as per the recommendations for the application of Ardex WPM 001 to floors.

Walls

Two coats of Ardex WPM 001 are required to achieve a minimum total dry film thickness of 0.5mm.

After priming with Ardex WPM 265 and allowing to dry, apply two coats of Ardex WPM 001 (to achieve a minimum dry film thickness of 0.5mm) in two opposite directions. Wall sheet joints should be treated with a neutral cure silicone, PVC duct tape or base jointing compound. In balcony situations take the membrane up underneath any existing cover flashing or install appropriate flashing. Allow the first coat to dry before applying the second coat.

Floors

Two coats of Ardex WPM 001 are required to achieve a minimum total dry film thickness of 1.0mm. The flooring recommendations should be extended at least 150 mm up all perimeter walls.

Prime the surface with Ardex WPM 265 and allow to dry.

Apply the first coat over the primed surface and allow it to dry (1-2 hours at 23°C, 50%RH) before applying a second coat in an opposite direction. In shower recesses a drainage flange must be installed on all timber/sheeted floors, and are strongly recommended on all other substrates. Where possible rebate the flange into the floor. Seal the perimeter of the flange with neutral cure silicone treatment. If a flange is not installed the membrane must be applied down into the pipe. (Refer Fig.5) Allow the membrane to dry completely before tiling. Refer drying times above.

Waste Outlet

Prime the surface with Ardex WPM 265 and allow to dry. Surfaces of the outlet flange must be primed with an appropriate primer.

Apply Ardex WPM 001 over the adjacent floor surface extending down into the waste outlet flange overlapping the edge of flange by at least 30mm. Place Ardex "Deckweb" polyester woven mat reinforcement over the applied membrane. Thoroughly wet out the cloth and remove all creases in, or air pockets under the mat. Immediately apply a second coat to completely fill the mat. (Refer Fig. 5)

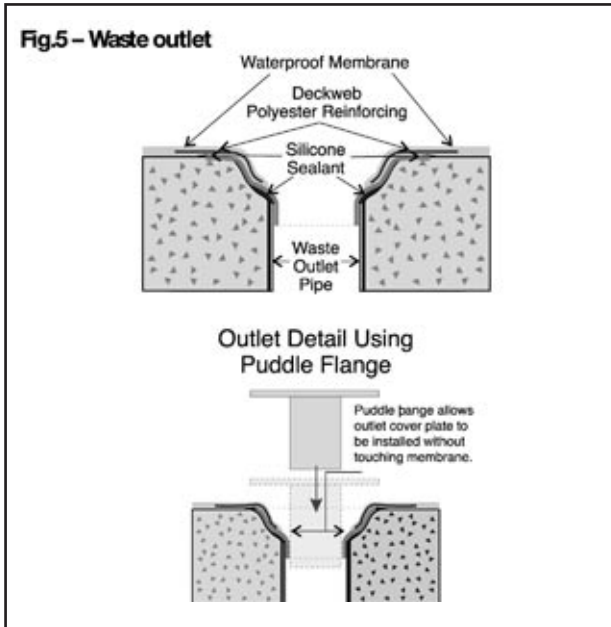

Balcony penetrations (Refer Fig.6)

All upstands are to be mechanically fixed through the membrane, which must be fabricated with a base plate flange.

Prime the metal with an appropriate metal primer such as an epoxy polyamide primer and allow to dry. Apply a 10mm bead of neutral cure silicone around the perimeter of the penetration. Apply the first coat of Ardex WPM 001 on the substrate and the flanged metal.

Allow first coat to dry before applying a second coat ensuring a finished dry film thickness of no less than 1.0mm is achieved. Place a suitable flashing collar around the penetration sealing it with a suitable sealant.

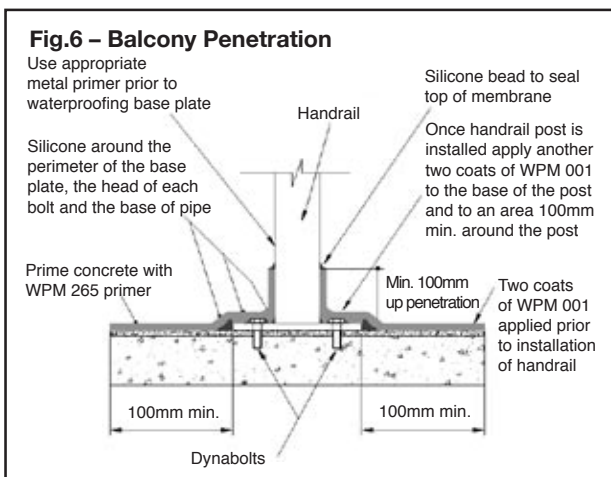

Tiling systems

It is advisable to conduct a flood test of the shower once the membrane has cured (normally after 72 hours), and before the tiling commences. A broad range of Ardex tile adhesives can be used over Ardex membranes. Contact Ardex or your nearest Ardex stockist for advice on the most suitable system.

TECHNICAL DATA

Ardex WPM 001 (Superflex Premixed) Characteristics of liquid

Form & Colour	Blue viscous paste
Type	Single part
Specific Gravity	Approx. 1.34kg/litre
pH of Liquid	8.5
Viscosity of Liquid (RVT Brookfield, spindle 7 speed 10)	52,000cps
Non Volatile Matter (volume) AS1321.10	50.3%±1
Tensile Strength 7 days dry AS1145	1.04 MPa
Full Cure	1.92 MPa
Elongation at Break 7 days dry AS1145	780%

Conforms to requirements of class 3 membrane of AS/NZ 4858: 2004 Wet Area Membranes.

NOTE: Most of the tests have been carried out in the Ardex laboratory under standard conditions (23±2°C, 50±5% R.H)



ARDEX WPM 002

Superflex Bathroom & Balcony - 2 Part

2 Part Undertile Waterproofing Membrane

BRANZ Appraised

Rapid Drying Time

Two Component Undertile Waterproofing Membrane

Advanced acrylic – will not re-emulsify

Liquid reinforced – eliminates the need for reinforcing mat

Water based – safe to use, low odour and easy cleaning

Meets class III category for AS/NZ 4858 Wet Area Membranes

Low VOC content – meets Green Building Council of Australia
Green Star IEQ-13 requirements

ARDEX WPM 002

Superflex Bathroom & Balcony - 2 Part 2 Part Undertile Waterproofing Membrane



Copies available on request.

PRODUCT DESCRIPTION

Ardex WPM 002 (Superflex Bathroom & Balcony 2 Part) is a tough, fast drying two component waterproofing membrane specifically designed for use under tiles. The product has been uniquely formulated with synthetic microfibres to increase its strength and eliminate the need for a separate reinforcement mat. Ardex WPM 002 is based on the most advanced acrylic polymer technology, and is totally resistant to re-emulsification.

Ardex WPM 002 is flexible, safe to use, low in odour, and is fully compatible with polymer modified tile adhesives. Ardex WPM 002 is one of the fastest drying acrylic membranes on the market – normally ready to tile in 16-24 hours @ 23°C.

WPM 002 meets the Green Building Council of Australia Green Star IEQ-13 requirements for Architectural Sealant when tested in accordance with SCAQMD Method 304-91 Determination of Volatile Organic Compounds (VOC) in Various Materials as referenced by South Coast Air Quality Management Division (SCAQMD) Rule 1168.

FEATURES/BENEFITS

Fast drying Ardex WPM 002 can be tiled over in 16-24 hours, or 4 hours @ 23°C/50% RH in non critical areas*.

Features benefits

- Liquid reinforced: Excellent strength, eliminates need for reinforcing mat.
- Flexible: Accommodates normal building movement.
- Advanced acrylic: Will not re-emulsify.
- Designed for tiling: Fully compatible with ABA/Ardex tile systems adhesives.
- Water based, safe to use, low odour and easy cleaning for undertile waterproofing in shower recesses by independent testing authority.
- Excellent exterior.
- Conforms to the requirements of AS/NZ 4858: 2004 Wet Area Membranes (Ref: CSIRO Report 3879)

*Critical areas include areas where the membrane is applied at greater than 0.5mm or over impermeable substances such as over bond breakers or incorporating other reinforcement. Longer drying times are necessary in these areas.

APPLICATION RANGE

Performance levels

Commercial and residential.

Location

Internal and external wet areas, balconies, decks, and other areas that will be tiled or otherwise protected from regular foot traffic.

Surfaces

Walls and floors.

Substrates

Concrete	Cured for min. 28 days or sealed when set with one coat Ardex WPM 300 (HydrEpoxy 300) at a coverage rate of 3.0 square metres per litre and allowed to cure overnight. Wet concrete should be allowed to dry thoroughly or sealed with one coat of Ardex WPM 300 as above.
Renders and screeds	Cured for min. 7 days or sealed when set with one coat Ardex WPM 300 at a coverage rate of 3.0 square metres per litre and allowed to cure overnight. Wet render should be allowed to dry thoroughly or sealed with one coat of Ardex WPM 300 as above.
Fibre cement	Wet area grade only.
Plasterboard	Wet area grade only.
Plywood	Structural plywood (PAA branded) or marine grade or other wet area grade only. Not recommended for external use (refer Ardex).
Particleboard	Wet area grade, internal use only (special preparation is required – contact Ardex). Not recommended for external use (refer Ardex).
Permanent Immersion	In conditions of permanent immersion, it is recommended that WPM 002 must be covered with tiles for full immersion applications.

Contact Ardex for use over existing membranes, covering materials, and any other substrates not listed.

SPECIFICATION CLAUSE

Ardex WPM 002 (Superflex Two Part)

The waterproofing membrane shall be Ardex WPM 002, a two component cementitious acrylic modified fibre reinforced membrane formulated to provide a tough, long lasting water barrier under tiling systems.

PACKAGING

Two component: 20kg (approx 20 litres) liquid pail/
2 x 10kg bags powder.

TABLE 1

	Thickness per coat		Total dry film thickness (2 coats)	Theoretical coverage		Per unit
	Dry film	Wet film		Per coat	For 2 coats	
FLOORS	0.6mm	0.9mm	1.2mm	32m ²	16m ²	40kg kit
WALLS	0.4mm	0.6mm	0.8mm	48m ²	24m ²	40kg kit

SHELF LIFE

12 months when stored in the original unopened packaging, in a dry place at 23°C. Do not store in direct sunlight. Replace lid tightly after use. Use remaining contents from part used containers within 3 months.

COVERAGE

Two coats are recommended for an effective waterproof membrane. Coverage will vary depending on the porosity of the surface.

One 40kg kit will cover approximately 16-24m (based on two coats) depending on area requirements between wall and floor surfaces to be treated.

DRYING TIMES

Curing time will vary depending on temperature and humidity.

Recoat time

1-2 hours (23°C/50% RH) between first and second coats. Alternatively, if a polyester mat is used between coats then the second coat can be applied whilst the first coat is still wet.

Dry through

The slowest drying areas are those where the membrane has been applied over a silicone bond breaker, eg. wall and floor junctions. The membrane cannot be tiled over until these critical areas are completely dry.

Ardex WPM 002 membrane is totally dry in 16 hours at 23°C/50% RH but can take up to 24 hours at 10°C / 50% RH in corners or for thick films.

In areas where bond breakers or additional reinforcement are not used, Ardex WPM 002 can be tiled over after 4 hours at 23°C / 50% RH.

Fully cured

The shower should not be used until the membrane has reached its full strength. Normally Ardex WPM 002 membranes are fully cured after 3 days at 23°C, or after 5 days at 10°C.

Drying times will vary depending on humidity, surface temperature and surface porosity.

Do not apply on substrates where the surface temperature is below 10°C or above 35°C.

CLEANING

Wash hands, brushes, rollers, etc, with water while the membrane is still fresh. Remove cured material with mineral turpentine.

SAFETY PRECAUTIONS

Do not use the product in the following situations:

- Areas subject to negative hydrostatic pressure or rising damp, unless treated with Ardex WPM 300.
- Where the substrate is wet – wet surfaces can be sealed with one coat of Ardex WPM 300 at a coverage rate of 3.0 square metres per litre and allowed to cure overnight.
- Where rain is imminent.
- Where the membrane will be left exposed and subjected to regular foot traffic.
- On glazed, glass or other totally impervious surfaces (eg. areas pre-treated with water repellants).
- Where the surface temperature is below 10°C or greater than 35°C.
- All floor areas must have adequate falls either built into the substrate or achieved with a sand/cement screed prior to application of the Ardex WPM 002.

For substrates or situations other than those listed contact Ardex.

SAFETY DATA

Ardex WPM 002 Part A is non-hazardous. It may produce discomfort of the eyes, respiratory tract and skin. It should not be swallowed or inhaled. Avoid contact with skin and wear eye/face protection. In case of contact with eyes, rinse with plenty of water and contact a doctor or Poisons Information Centre.

Ardex WPM 002 Part B contains cement and is therefore hazardous. It may cause burns and serious damage to eyes. Do not breathe dust and avoid contact with eyes. Wear dust masks, goggles and gloves when handling. Keep container locked up and in a well ventilated place.

ADDITIONAL INFORMATION IS LISTED IN THE MATERIAL SAFETY DATA SHEET.

ARDEX WPM 002

Superflex Bathroom & Balcony - 2 Part 2 Part Undertile Waterproofing Membrane

APPLICATION

Apply Ardex WPM 002 by brush or roller. A medium nap (12–15mm pile) paint roller is recommended. New rollers should be dampened with water before being used for the first time.

For best results with a paint brush use a good quality, 50mm long bristle variety.

To achieve the required dry film thickness per coat application must consist of laying the product onto the surface and light finish the surface. Do not try to apply in the same manner as a building paint. A conventional building paint is normally applied at 25–40 micrometers wet film thickness while Ardex WPM 002 needs to be applied at between 0.6 and 0.9 mm per coat depending on product and application (Refer Table 1).

Critical areas:

INTERNAL WET AREAS

1. Construction should be in accordance with Australian 3740 - 2004 Waterproofing of wet areas within residential buildings.
2. All render and tile bed requirements should be completed before application of the membrane and tiles or other floor coverings should be direct bonded to the membrane.
3. Ensure wall and floor sheets are installed as per sheet manufacturer's recommendations.
4. Ensure suitable brick/concrete hobs are used (do not use timber), and that the top of the hob does not slope outwards.
5. Ensure that falls to the waste are min 1:60 (ie. approx. 30mm in 2m) before waterproofing. Ensure outlet pipes are fixed securely and that the waste or drainage flanges are recessed into the floor.
6. Avoid sheet joints in shower recess floor. Ensure that sheets are securely fixed to the wall at the bottom edge, and sheet joints are sealed with a neutral cured silicone sealant spread approximately

6mm on either side of the joint.

7. Treat nail and screw holes with neutral cure silicone sealant.
8. Seal the perimeters of taps, shower outlets and waste outlets with neutral cure silicone sealant.
9. Apply a bead of neutral cure silicone sealant to all horizontal and vertical corners, and spread to 6mm on either side of joint.
10. Apply a bead of neutral cure silicone sealant to the junction of the hob or angle and walls, and spread to 6mm on either side of joint.
11. Waste outlets shall incorporate a puddle flange or similar in accordance with AS3740 and the top surface shall be set flush with the surface to which the membrane is to be applied. A bead of neutral cure silicone shall be applied across the intersection of the puddle flange and the screed/floor.
12. Apply the membrane to the entire shower recess floor and down into waste or drainage flange. Apply the membrane over the hob and at least 150mm beyond the outside edge of the hob (ideally to entire wet area floor).
13. Apply the membrane 1800mm up the walls or to the height of the shower rose within the shower recess.
14. Install the shower screen to inside edge of the hob.

BALCONIES AND DECKS

1. Ensure that the deck is constructed with falls to edge/drains of min 1:100 (ie. 20mm in 2m) or else achieve the fall with a sand/cement screed.
2. Ensure a min set down (step down) of 50mm to the finished floor level (ie. top of tiles).
3. Ensure suitable flashing is installed, ideally prior to the installation of the balcony screen/sliding door.
4. Treat any sheet joints with a neutral cure silicone

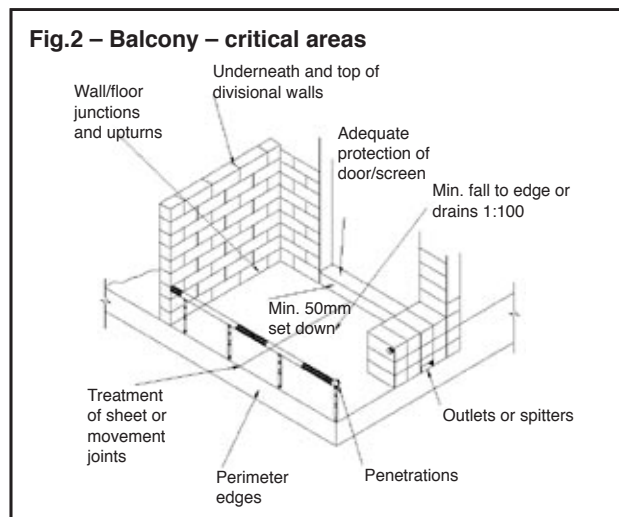
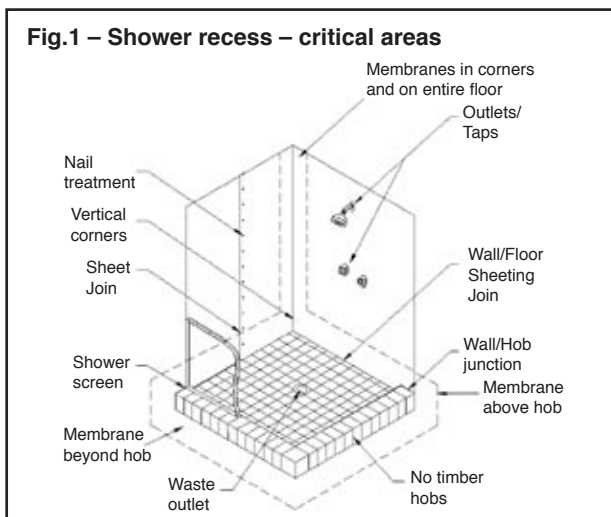

- prior to waterproofing.
5. Prepare and seal all wall/floor junctions with a bead of neutral cure silicone.
 6. Apply the membrane up the step down and as far up underneath the screen door flashing as possible (ideally waterproof prior to installing door).
 7. Where possible, apply the membrane prior to building divisional walls.
 8. Apply the membrane to the entire balcony floor and at least 50mm up the wall above the top surface of the finished tiles and finished below the wall drainage vents.
 9. Apply the membrane to the top of the parapets and divisional walls, or else install suitable metal capping.
 10. Apply the membrane down over the front edge of the balcony onto the drip rail.
 11. Carefully seal any gaps around balcony penetrations prior to applying the membrane.
 12. Apply the membrane down into outlets and drains, ensuring excess material is removed.
 13. Ensure all weep holes are above the membrane application area.

APPLICATION NOTES

Surface preparation

- Ensure all surfaces are structurally sound and totally dry. The pores of concrete surfaces should be open (absorbent surface). All sheet substrates must be securely fixed in accordance with the manufacturers instructions.
- Falls to outlets of at least 1:60 or approx. 30mm in 2m (wet areas) or 1:100 externally, must be achieved prior to tiling.
- The surface to be coated should be free from dust, oil, paint, curing compounds and any other contaminating materials.
- Damaged concrete should be repaired (leveled) and surface defects including all cracks and sharp protrusions should be treated prior to the application of the membrane.
- Remove laitance on concrete or screeds by mechanical means.
- Highly dense (>40MPa) or steel trowelled concrete should be roughened by suitable mechanical means (shot blasting, grinding, etc).

Priming

The primer is a critical part of the waterproofing system. Apply one coat of Ardex WPM 265 (Sheltercoat/Superflex Water Based Primer) by brush or roller to all areas to be waterproofed including the floor

waste. Allow the primer to be completely dry prior to the application of the Ardex WPM 002 membrane. This will take around 20-30 minutes depending upon weather conditions and porosity of the substrate. Coverage is approximately 6m² per litre. Plastic (eg. PVC) pipes should be primed with a solvent based plumbers pink primer. Prime metal surfaces with a suitable metal primer such as epoxy polyamide primer.

GENERAL APPLICATION

Crack preparation

Cracks <2mm:

Clean and remove any loose particles in the crack. Prime the crack and adjacent area carefully with Ardex WPM 265 and allow to dry before applying two coats of Ardex WPM 002 membrane, in a band at least 200mm wide equidistantly across the crack, along the length of the crack.

Cracks 2-6mm:

(Refer Fig. 3) prepare and prime the crack as above. Apply a bead of neutral cure silicone into the crack and extend it 6mm either side. Apply a 300mm wide band of Ardex WPM 002 equidistantly across the crack along the entire length of the crack. Place a 190mm wide band of Ardex "Deckweb" polyester woven cloth reinforcement over the applied membrane. Thoroughly wet out the cloth and remove all creases in, or air pockets under the mat. Immediately apply a second coat to completely fill the mat.

Cracks >6mm:

Contact your local Ardex representative.

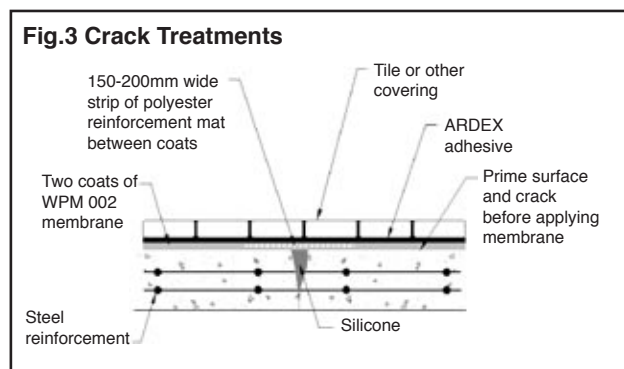

ARDEX WPM 002

Superflex Bathroom & Balcony - 2 Part 2 Part Undertile Waterproofing Membrane

Movement/construction joints

Movement joints (<6mm)

Clean and prime the joint before filling it with a bead of neutral cure silicone and extending it 6mm each side of joint. Apply a 300mm wide band of Ardex WPM 002 equidistantly across the crack along the entire length of the crack. Place a 190mm wide band of Ardex "Deckweb" polyester woven cloth reinforcement over the applied membrane. Thoroughly wet out the cloth and remove all creases in, or air pockets under the mat. Immediately apply a second coat to completely fill the mat.

Construction joints (>6mm)

Use the same procedure as above, but replace the reinforcing mat with 120mm of Ardex Coving Bandage. Note: if tiling, movement joints should be taken to the surface of the tiles. Fill the joints between the tiles immediately above the movement joints with an appropriate joint sealant. (Refer Fig.4)

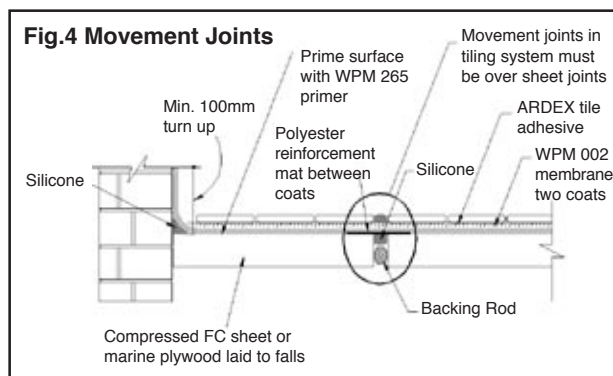

Corners and coving areas

After priming with Ardex WPM 265 and allowing to dry, apply a generous bead (16mm) of neutral cure silicone sealant in coving areas and corners. (Refer Fig.5) Smooth over the silicone so that it extends 8mm up the wall and 8mm over the floor and allow to touch dry.

Apply a first coat of Ardex WPM 002 to the area and allow the membrane to dry.

Apply a second coat ensuring that excess product is removed from the junction (the final dry film thickness should be around 1.2mm) Alternatively, if a polyester reinforcement mat is used between coats then the second coat can be applied as soon as the mat is fully bedded into the first coat.

WALL/FLOOR JUNCTION

After priming with Ardex Superflex WPM 265 and allowing to dry, apply a generous bead (16mm) of neutral cure silicone sealant to seal all junctions between two substrates. Smooth over the silicone so that it extends 8mm up the wall and 8mm over the floor and allow to touch dry. Place a 190mm wide band of

Ardex "Deckweb" polyester woven cloth reinforcement over the applied membrane. Thoroughly wet out the cloth and remove all creases in, or air pockets under the mat. Immediately apply a second coat to completely fill the mat. The Ardex WPM 002 should be applied to at least 150mm up the wall surfaces as per the recommendations for the application of Ardex WPM 002 to floors.

Walls

Two coats of Ardex WPM 002 are required to achieve a minimum total dry film thickness of 0.8mm.

After priming with Ardex Superflex WPM 265 and allowing to dry, apply two coats of Ardex WPM 002 (to achieve a minimum dry film thickness of 0.8mm) in two opposite directions. Wall sheets joints should be treated with a neutral cure silicone, PVC duct tape or base jointing compound. In balcony situations take the membrane up underneath any existing cover flashing or install appropriate flashing. Allow the first coat to dry before applying the second coat.

Floors

Two coats of Ardex WPM 002 are required to achieve a minimum total dry film thickness of 1.2mm. The flooring recommendations should be extended at least 150mm up all perimeter walls.

Prime the surface with Ardex WPM 265 water based primer and allow to dry.

Apply the first coat over the primed surface and allow it to dry (1-2 hours at 23°C, 50% RH) before applying a second coat in an opposite direction. In shower recesses a drainage flange must be installed on all timber/sheeted floors, and are strongly recommended on all other substrates. Where possible rebate the flange into the floor. Seal the perimeter of the flange with neutral cure silicone treatment. If a flange is not installed the membrane must be applied down into the pipe. (Refer Fig.5) Allow the membrane to dry completely before tiling. Refer drying times above.

Waste outlet

Prime the surface with Ardex WPM 265 and allow to dry. Surfaces of outlet flange must be primed with an appropriate primer.

Apply Ardex WPM 002 over the adjacent floor surface extending down into the waste outlet pipe overlapping the pipe surfaces by at least 30mm. Place Ardex "Deckweb" polyester woven cloth reinforcement over the applied membrane. Thoroughly wet out the cloth and remove all creases in, or air pockets under the mat. Immediately apply a second coat to completely fill the mat. (Refer Fig. 5).

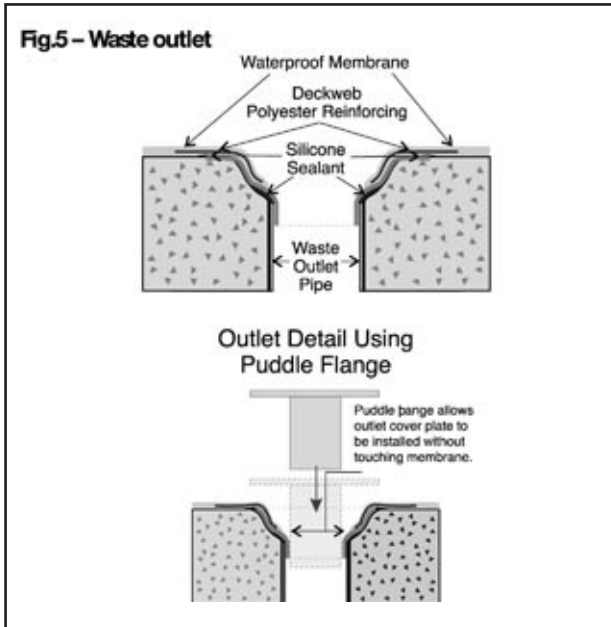

Balcony penetrations (Refer Fig.6)

All upstands are to be mechanically fixed through the membrane, which must be fabricated with a base plate flange.

Prime the metal with an appropriate metal primer such as an epoxy polyamide primer and allow to dry. Apply a 10mm bead of neutral cure silicone around the perimeter of the penetration. Apply the first coat of Ardex WPM 002 on the substrate and the flanged metal.

Allow first coat to dry before applying a second coat ensuring a finished dry film thickness of no less than 1.2mm is achieved. Place a suitable flashing collar around the penetration sealing it with a suitable sealant.

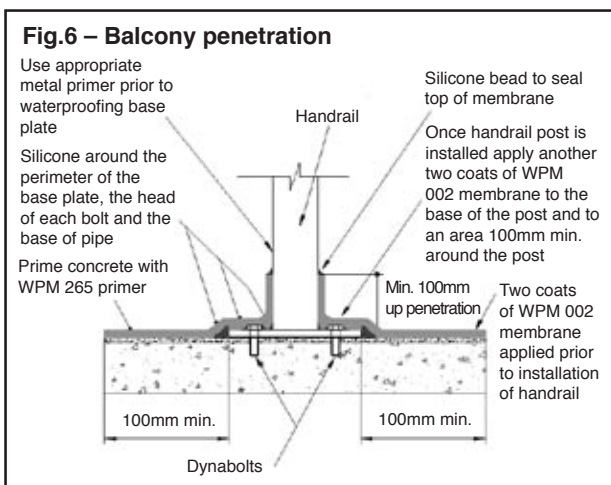

Tiling systems

It is advisable to conduct a flood test of the shower once the membrane has cured (normally after 48 hours), and before the tiling commences. A broad range of Ardex tile adhesives can be used over Ardex Superflex membranes. Contact Ardex or your nearest Ardex stockist for advice on the most suitable system.

QUALITY PRODUCT

Ardex WPM 002 is manufactured and tested to Ardex procedures which are maintained in accordance with Quality System Standard ISO 9001.

USER NOTES

The technical details and recommendations contained in this data sheet are given in good faith and represent the best of our knowledge and experience at the time of printing. It is the responsibility of the user to ensure that the product is used in accordance with Ardex instructions and in applications for which they are intended.

TECHNICAL DATA

Ardex WPM 002

Characteristics of components

Form & Colour	Liquid: white, medium viscosity Powder: off white
---------------	--

Characteristics of mixed product

Mixing Ratio	1:1 by weight
--------------	---------------

SG of mixed product	1.44kg/litre
---------------------	--------------

Non Volatile Matter	77±1%
---------------------	-------

Colour	light grey/green
--------	------------------

Characteristics of cured membrane

Shore A hardness ASTM D2240

– dry film	85 – 90
– wet film	75 – 80

Tensile Strength

7 days dry AS1145	1.7 MPa
-------------------	---------

Full Cure 28 days:	2.9 MPa
--------------------	---------

Elongation at Break

7 days dry AS1145	332%
-------------------	------

NOTE: Most of the tests have been carried out in the Ardex laboratory under standard conditions (23±2°C, 50±5% RH)