

NOTE:
FLANGE PREPARED USING
ARDEX WPM 299

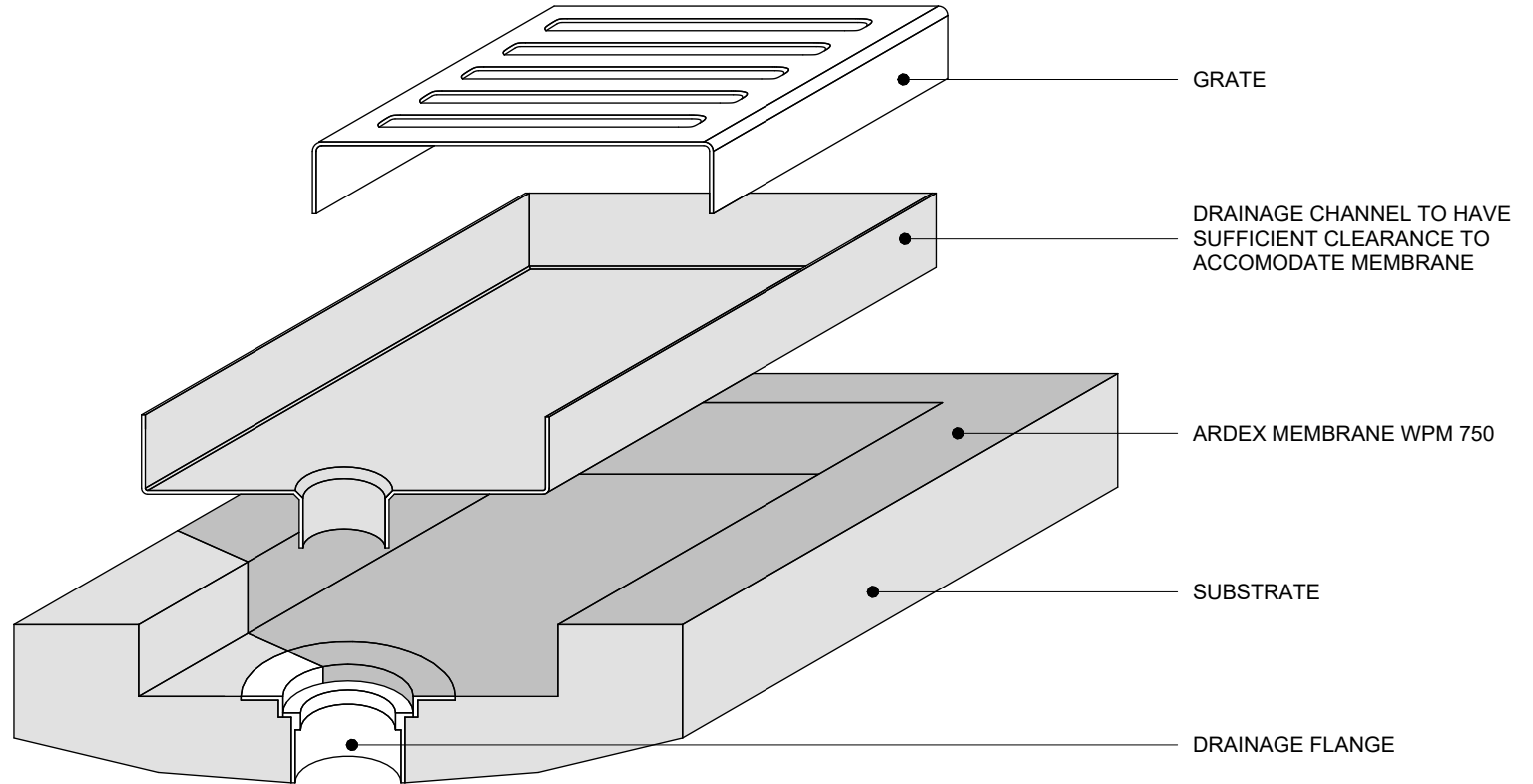

WET AREA WATERPROOFING

TYPICAL MEMBRANE TERMINATION AT DRAINAGE CHANNEL

DWG NO. **AWW-14**

DATE 03.2026
SCALE 1 : 2 @ A4



Disclaimer: Ardex makes every reasonable effort to ensure that the technical details, recommendations and other information contained in this drawing are accurate and represent our knowledge and experience at the time of design and publication. Ardex reserves the right to change the information without prior notice. Ardex provides the information in good faith with no representations or warranties (whether implied or otherwise), and will not be liable for any losses or damages (whether direct, indirect or consequential) whatsoever, whether in contract, negligence or any other action, arising out of or in connection with the use, or inability to use, the information. It is your responsibility to ensure that our products are used only for the purposes for which they are intended and are used in accordance with any applicable specifications, guidelines, standards, codes of practice, regulations and laws. The supply of our products and services are also subject to certain terms, warranties and exclusions which are available on request.